

# STUDENT HANDBOOK

2022 - 2023

Jefferson College   
College





# **DIVERSITY/INCLUSION AND NON-DISCRIMINATION POLICY**

## **OUR COMMITMENT TO DIVERSITY AND INCLUSION**

Jefferson College is a community leader dedicated to supporting and promoting diversity through opportunities and experiences that foster a culture of respect, inclusiveness, and understanding for everyone in the campus community to engage in a diverse world.

Diversity and inclusion at Jefferson College is a collective effort that comes from staff, faculty, and students working together to make sure our campus is a welcoming place for all people, regardless of background or identity.

## **NON-DISCRIMINATION POLICY**

It is the policy of Jefferson College that no person shall, on the basis of age, ancestry, color, creed, disability, genetic information, marital status, national origin, race, religion, sex, gender identity or expression, sexual orientation, or veteran status, be subject to discrimination in employment or in admission to any educational program or activity of the College.

In compliance with Federal Rules and Regulations, Jefferson College has adopted a procedure for resolving complaints of discrimination. The procedure is available to any Jefferson College [student](#), [employee](#), or [applicant](#) who feels they have been discriminated against in employment, student programs, or student activities. For matters involving sexual harassment, please refer to the Jefferson College Title IX Sexual Harassment Procedure and Grievance Process for [students](#) and [employees](#).

- The Americans with Disabilities Act Amendments Act (ADAAA) Coordinator for students is the Disability Support Services Coordinator, Linda Ladendecker-Corley, Office — Technology Center 101, [lladende@jeffco.edu](mailto:lladende@jeffco.edu), (636) 481-3169/797-3000, ext. 3169.
- The College Coordinator of Title IX is Dr. Kimberly Harvey-Manus, Office — Student Center 205, [kharvey@jeffco.edu](mailto:kharvey@jeffco.edu), (636) 481-3200/797-3000, ext. 3200. The College Coordinator of Title IX is responsible for any alleged discrimination or harassment that relates to sex or gender, including, but not limited to sexual harassment, sexual discrimination, and sexual misconduct complaints.
- Students with concerns regarding any alleged discriminatory act or occurrence falling within the provisions of any of the Federal Rules and Regulations other than Title IX or ADAAA as specified above may contact Dr. Kimberly Harvey-Manus, Office — Student Center 205, [kharvey@jeffco.edu](mailto:kharvey@jeffco.edu), (636) 481-3200/797-3000, ext. 3200.
- Employees, applicants, or other individuals with concerns regarding any alleged discriminatory act or occurrence falling within the provisions of any of the Federal Rules and Regulations other than Title IX or ADAAA as specified above may contact the Director of Human Resources, Tasha Welsh, Office — Administration 133-E, [twelsh@jeffco.edu](mailto:twelsh@jeffco.edu), (636) 481-3157/797-3000, ext. 3157.
- Reports may be made in person, verbally, by phone, in writing through mail or electronic mail, through the College's [Maxient reporting portal](#) (found in MyJeffco or at [www.jeffco.edu/non-discrimination-policy](http://www.jeffco.edu/non-discrimination-policy)), or any other manner that delivers the information to the appropriate Coordinator at any time.

# **ACCREDITATION**

## **Specific programs are accredited/approved by the following organizations:**

- Accreditation Council for Occupational Therapy Education
- American Veterinary Medical Association
- Automotive Service Excellence (ASE)
- College Reading and Learning Association
- Commission on Accreditation for Health Informatics and Information Management Education
- Commission on Accreditation in Physical Therapy Education
- Commission on Accreditation for Law Enforcement Agencies
- Committee on Accreditation of Education Programs for the Emergency Medical Services Professions
- HVAC Excellence
- Joint Review Committee on Education in Radiologic Technology
- Missouri Accreditation of Programs for Children and Youth
- Missouri Department of Elementary and Secondary Education
- Missouri Division of Emergency Medical Services
- Missouri State Board of Nursing

## **Jefferson College's institutional affiliations include:**

- American Association of Community Colleges
- American Association of Community College Trustees
- American Registry of Radiologic Technologists
- American Welding Society
- Missouri Association of Career and Technical Education
- Missouri Community College Association
- Missouri Department of Elementary and Secondary Education (DESE)
- Missouri Department of Public Safety (POST) – Peace Officers and Standards Training Commission
- Missouri School-College Relations Association
- National Alliance of Concurrent Enrollment Partnerships
- National Institute for Metalworking Skills (NIMS)
- National Junior College Athletic Association
- St. Louis Astronomical Society
- The Higher Learning Commission
- United Brotherhood of Carpenters

Jefferson College is accredited by The Higher Learning Commission. Individuals should direct their questions, comments, or concerns to 230 South LaSalle Street, Suite 7-500, Chicago, IL 60604-1411. (800) 621-7440 or (312) 263-0456; Fax (312) 263-7462.

# **CONTENTS**

Directory of Services – Hillsboro .....	5
Directory of Services – Arnold .....	6
Directory of Services – Imperial .....	6
Mission Statement.....	7
Questions & Answers.....	7
Get Involved in Student Organizations .....	8
Sports at Jefferson College .....	10
Field House Activity Guidelines .....	10
Services for Students.....	11
Academic Support Services for Students.....	13
Library Services .....	15
Online Courses.....	16
Student Code of Conduct.....	16
Rules of Procedure for Violations of the Student Code of Conduct .....	17
Recommended Procedures Survivors Should Follow in the Case of Alleged Dating Violence, Domestic Violence, Sexual Assault, or Stalking.....	21
Complaints Alleging Discrimination or Harassment Procedure.....	28
Title IX Sexual Harassment Procedure and Grievance Process .....	31
Prohibition Policy Against Drug and Alcohol Abuse .....	48
Academic Computer Use Policy.....	49
Cell Phone Use in Classrooms .....	51
Official Student Records.....	51
Notification of Rights Under FERPA.....	51
Student Appeal Process for Misapplication of College Policies, Procedures, & Practices .....	52
Availability of Federal Disclosure Information .....	53
Minimum Standards of Academic Progress.....	54
Financial Aid Guidelines.....	55
U.S. Department of Education Return of Title IV Funds Policy .....	57
Class Attendance Policy.....	58
Administrative Withdrawal.....	58
Financial Aid Implications Related to Attendance.....	58
Withdrawing, Dropping, and Adding Courses.....	59
Request for Medical Withdrawal .....	59
Grade Appeal Process .....	59
Campus Who’s Who .....	60
Faculty Office Hours.....	60
Drug-Free Work Place Guidelines .....	60
Agreement for Success .....	61
Academic Calendar 2022-2023.....	62
Index .....	63
Floor Plans/Evacuation Routes .....	64

## **STUDENT HANDBOOK**

The contents of this handbook are provided for informational purposes. The handbook is accurate at the time of posting but is subject to change. Any such changes may be implemented without prior notice and are effective when made. Students will be notified via email of any substantive changes to this handbook, including information about accessing these updates. Jefferson College reserves the right to terminate programs for financial or other reasons which the College determines warranted. The programs, services, or other activities of the College may be terminated at any time due to reasons beyond the control of the College, including—but not limited to—acts of God, natural disasters, destruction of premises, labor disturbances, governmental orders, or financial insolvency.



# DIRECTORY OF SERVICES – HILLSBORO

Telephone: (636) 481-3000 or (636) 797-3000

TTY users dial 711 • FAX (636) 789-5103

**Where extensions are listed, please dial (636) 481-XXXX**

*(When dialing from an on-campus phone, only the 4-digit extension is needed)*

<b>AREA</b>	<b>EXT.</b>	<b>BLDG</b>
<b>Academic Success Center</b>	3439	Tech Center 1st Floor
• Computer Information Systems Lab		Tech Center 103
• Math Lab		Tech Center 107
• Science Lab		Tech Center 107
• Writing Lab		Tech Center 105
<b>Admissions</b>	3235	Student Center 1st Floor
<b>Adult Education and Literacy (GED)</b>	3437	Hillsboro: Tech Center 305 Arnold: Room 301
<b>Bookstore</b>	3251	Student Center Low Level
<b>Campus Police</b>	3500	Viking Woods 214
<b>Cashier</b>	3123	Student Center 145
<b>Early Childhood Center</b>	3298/3299	Early Childhood Center
<b>Counseling Services</b>	3215	Student Center Top Floor
<b>Dean of Instruction</b>	3467	Tech Center 205
<b>Disability Support Services</b>	3158	Tech Center 101
<b>Enrollment Services:</b>	3209	Student Center 1st Floor
• Advising		
• Career		
• Financial Aid		
• Registration		
• Student Records		
• Transfer		
<b>Financial Aid</b>	3212	Student Center 1st Floor
<b>Library</b>	3166	Library
<b>Micro Mart Food Services</b>		Career & Tech Education 144D
<b>Missouri Baptist University</b>	3214/3242	Student Center Lower Level
<b>Project SUCCESS</b>	3281	Student Center Top Floor
<b>Student Conduct &amp; Care Team</b>	3262	Student Center Top Floor
<b>Student Development</b>	3231	Student Center Lower Level
<b>Technology/MyJeffco Help Desk</b>	3234	
<b>Testing Center</b>	3147/3148	Southeast corner of the Library building
<b>Title IX</b>	3200	Student Center 205
<b>Tuition Payment - Cashier</b>	3123	Student Center 1st Floor
<b>University of Missouri-St. Louis</b>	3243/3244	Arts & Science I 110
<b>Veterans' Education Benefits</b>	3285	Student Center 1st Floor
<b>VP of Instruction</b>	3300/3301	Administration 131
<b>VP of Student Services</b>	3200/3201	Student Center 205
<b>Workforce and Employment Services</b>	3144	Career & Tech Education 101
• Job search assistance and non-credit programs		

**Gender-neutral restrooms are located in the following areas on the Hillsboro campus:**

- AS II - First floor restrooms next to Online Learning located in Room 303
- CTE - Main level restrooms next to Room 174
- Library - First floor single-use restroom down the hallway next to the Circulation Desk

**Lactation rooms are located in the following areas on the Hillsboro campus:**

- ASI - Room #107D, see Tina Jokerst, Room #110.
- CTE - Room #142D, left unlocked.
- Library - Two rooms available, see Library Staff.

## **JEFFERSON COLLEGE – ARNOLD EXT. 3597**

Where extensions are listed, please dial (636) 481-XXXX  
*(When dialing from an on-campus phone, only the 4-digit extension is needed)*

<b>AREA</b>	<b>EXT.</b>	<b>ROOM</b>
Academic Advising	3597	1st Floor
Academic Support Center	3573	310B
Bookstore	3554	102
Central Methodist University	3598	231
Enrollment Services (Admissions, Registration, General Information)	3597	1st Floor
Micro Mart Food Services		Breakroom
Missouri Baptist University	(636) 282-2470	229
Testing Center	3592	310

**Lactation rooms are located in the following areas on the Arnold campus:**

- Room #323D, left unlocked.

## **JEFFERSON COLLEGE – IMPERIAL EXT. 3481**

Where extensions are listed, please dial (636) 481-XXXX  
*(When dialing from an on-campus phone, only the 4-digit extension is needed)*

<b>AREA</b>	<b>EXT.</b>	<b>ROOM</b>
Computer Lab^ <i>subject to scheduled classroom use</i>		213
Front Desk	3481	
Law Enforcement Info	3425	
EMT/Paramedic Info	3403	

*NOTE: All hours are subject to change. Please go to [www.jeffco.edu](http://www.jeffco.edu) for current information.  
 ^Computer Lab Schedule: [www.jeffco.edu](http://www.jeffco.edu) > Academics > Academic Services > Computer Labs*



# MISSION, VISION, VALUES

## **COLLEGE MISSION:**

Jefferson College serves our community by delivering quality learning opportunities that empower individuals to achieve their goals.

## **VISION:**

Jefferson College strives to inspire our community to explore, develop, and engage in innovative learning experiences in a supportive and inclusive environment.

## **VALUES:**

Jefferson College fosters a culture of excellence for its community of students, faculty, and staff by embracing the following values:

- **Success:** Supporting a focus on achievement, self-discovery, scholarship, creativity, completion, and skill mastery;
- **Accessibility:** Fostering an environment of diversity and inclusion where a culture of collaboration responds to the needs of our communities through quality and affordable educational opportunities;
- **Integrity:** Encouraging open, honest, and respectful communication; committing to accountability in all interactions, operations, and procedures;
- **Learning:** Establishing a high-quality learning environment that features collaborative and innovative engagement, academic freedom, professional development, and continuous assessment for improvement; and
- **Service:** Infusing a spirit of civil engagement through community volunteer initiatives, cultural enrichment, and Academic Service Learning opportunities.

# QUESTIONS & ANSWERS

## **SHOULD I DROP A CLASS OR WITHDRAW?**

There are several things you should consider before dropping or withdrawing from a class. If you receive FINANCIAL AID, dropping or withdrawing from the class may affect your eligibility, so check with Financial Aid before dropping or withdrawing. Talk to your INSTRUCTOR about the class, perhaps things aren't as bad as they seem. Is this course a PREREQUISITE for another class that you will need later? Dropping or withdrawing from a class may delay your graduation or transfer plans. Additionally, the class may not be offered again when you need it. Some classes are only offered one semester a year. It may be another year before you can re-enroll in this class. The College provides FREE TUTORS for classes. Visit the Academic Success Center, and they may be able to help you through the difficult times!

## **WHERE DO I GET MY STUDENT ID?**

Students who are enrolled at Jefferson College will need a student identification card, which also serves as their Library card. These cards will be issued to new students, or for returning students, in the Student Center at Hillsboro, the Library Circulation Desk at Hillsboro, the front desk at Arnold, or at the Imperial campus. There is a fee for a replacement ID.

## **HOW DO I GET A PARKING STICKER?**

Pick up a registration form from Enrollment Services in Hillsboro or the main counter at other campus locations. Return the completed form to Enrollment Services and pay the parking sticker fee (\$10), with Cash or Check only, at the Cashier's Office. You may also pay online for the parking sticker with a credit card, debit card, or echeck by visiting [jeffco.edu/cashier](http://jeffco.edu/cashier).

## **HOW DO I FIND OUT IF CLASSES ARE CANCELLED?**

### **Inclement Weather Cancellation:**

Announcements concerning class cancellations are carried on the following radio stations: KJFF AM (1400) Festus, KREI AM (800) Farmington, KTJJ FM (98.5) Farmington, WIL FM (92.3) St. Louis, and WRTH AM (1430) St. Louis. Class cancellations

may also be accessed by calling the College at (636) 481-3000 or 797-3000 or by visiting [www.jeffco.edu](http://www.jeffco.edu). Additionally, text alerts will be sent to those enrolled in the Viking Text Message Service.

## HOW DO I SIGN UP FOR VIKING TEXT MESSAGE SERVICE?

To register for this service, you must log into your MyJeffco account, then click on the “Viking Text Message Service” button on the Home tab. You will be asked to enter your cell phone number and cellular carrier.

## CAN I BRING MY CHILDREN TO CLASS WITH ME?

Students are not permitted to bring children to class, nor should children be left unattended in the halls, offices, Library, Student Center, or outside on campus. The College reserves the right to protect the safety and welfare of unattended children. If students leave their children unattended, the College will institute appropriate action.

## IS SMOKING PERMITTED ON CAMPUS?

The use of tobacco and all smoke-related products (including cigarettes, cigars, pipe tobacco, smokeless/chewing tobacco, electronic cigarettes, herbal smoke products, hookahs, and beedies) is restricted to inside personal vehicles. The policy pertains to all students, faculty, staff, other employees, contractors, performers, and visitors. Those who violate the policy are subject to a \$25 fine. Visit [www.jeffco.edu/Smoke-Free-Campus](http://www.jeffco.edu/Smoke-Free-Campus) for more information.

## HOW DO I APPLY FOR GRADUATION?

Students are encouraged to apply for graduation when registering for their final semester to ensure all course requirements are met. Graduation applications are available through the Student Center, Jefferson College-Arnold, Jefferson College-Imperial, on the Jefferson College website, and on the Student tab in MyJeffco. **Deadlines to apply for graduation are September 1 for fall/winter intersession, February 1 for spring/summer intersession, and June 1 for summer.**

## GET INVOLVED IN STUDENT ORGANIZATIONS!

- **Get connected to Jefferson College**
- **Become a leader**
- **Develop lasting friendships**
- **Learn valuable skills**

Joining a campus club or organization provides an excellent opportunity to meet people, develop skills, and have fun! General information about clubs and organizations is available in the Student Development Office on the lower level of the Student Center, or by calling (636) 481-3231.

The following is a list of current clubs and organizations with contact information. Also, check out the “Get Involved” page at [www.jeffco.edu/student-clubs](http://www.jeffco.edu/student-clubs).

- **BLACK STUDENT UNION** is designed to heighten the cultural, educational, and civic consciousness of African American students at Jefferson College.  
Contact Richard Stephenson [rstephe4@jeffco.edu](mailto:rstephe4@jeffco.edu) or Maryanne Angliongto [manglion@jeffco.edu](mailto:manglion@jeffco.edu)
- **JC NAVIGATORS** is a campus Christian organization that promotes fellowship through Bible study, discussions, and engagement in community service opportunities.  
Contact Fran Moore [fmoore1@jeffco.edu](mailto:fmoore1@jeffco.edu) or David Smith [dsmith70@jeffco.edu](mailto:dsmith70@jeffco.edu)
- **JC WRITING CLUB** provides a supportive environment where creative writers can learn, write, share, and improve. The goal is to nurture confident, successful writers with publishing credits.  
Contact Lisa Ebert [eebert1@jeffco.edu](mailto:eebert1@jeffco.edu)



- **LEGION OF GAMERS** is a group invested in promoting a sense of community and teamwork through participation in various games, building positive relationships, and bringing people together from diverse backgrounds.  
Contact Sarah Lafser [slafser@jeffco.edu](mailto:slafser@jeffco.edu)
- **LGBTQ+** is group composed of LGBT individuals as well as allies seeking to raise awareness of issues relevant to LGBT communities, as well as broader issues of acceptance and social justice.  
Contact Joe Kohlburn [jkohlbur@jeffco.edu](mailto:jkohlbur@jeffco.edu) or Elke Overton [eoverton@jeffco.edu](mailto:eoverton@jeffco.edu)
- **NATIONAL ASSOCIATION FOR MUSIC EDUCATORS (NAfME)** is a group for music majors with organizational goals of promoting music education, gaining professional experiences, and participating in networking opportunities.  
Contact Joel Vanderheyden [jvanderh@jeffco.edu](mailto:jvanderh@jeffco.edu) or Elke Overton [eoverton@jeffco.edu](mailto:eoverton@jeffco.edu)
- **NATIONAL SOCIETY OF LEADERSHIP & SUCCESS (NSLS)** teaches the interpersonal skills that employers seek to give you an edge in the job market. Hear directly from current members as they share how their experience has changed their life.  
Contact Brandi Gallaway [bgallawa@jeffco.edu](mailto:bgallawa@jeffco.edu)
- **PHI THETA KAPPA** is the international honor society for two-year colleges. The purpose of the group is to recognize and promote academic achievement among students.  
Contact Bruce Korbesmeyer [bkorbesm@jeffco.edu](mailto:bkorbesm@jeffco.edu) or Shannon Sniegolski [ssniegol@jeffco.edu](mailto:ssniegol@jeffco.edu)
- **PSYCHOLOGY CLUB** educates and stimulates interest in the field of Psychology through sharing information, discussion, debate, community service projects, and providing information about further education, professional organizations, and potential career paths.  
Contact Amy Kausler [akausler@jeffco.edu](mailto:akausler@jeffco.edu), Leslie Buck [lbuck@jeffco.edu](mailto:lbuck@jeffco.edu), or Brandon Whittington [bwhittin@jeffco.edu](mailto:bwhittin@jeffco.edu)
- **STUDENT NURSE CLUB** highlights the excellent choice of nursing as a career to students, the College and the community. Club members demonstrate their commitment to the club and their career by being actively involved in volunteer opportunities throughout the community and on campus. The club assists nursing students throughout their academic career by providing resources such as tutoring, study groups, and peer support.  
Contact Christine Kelly-Clark [ckellycl@jeffco.edu](mailto:ckellycl@jeffco.edu)
- **STUDENT MISSOURI NATIONAL EDUCATION ASSOCIATION (SMNEA) CLUB FOR FUTURE TEACHERS** provides students with opportunities to meet fellow prospective educators. The club activities promote leadership, community service, and the professional development of future teachers.  
Contact Ken Boning [kboning@jeffco.edu](mailto:kboning@jeffco.edu)
- **STUDENT SENATE** is the student governing body of Jefferson College and consists of students who are elected to represent the interests of students. Student Senators engage in leadership development, facilitate programs based on student requests and expressed needs, and advocate on behalf of students.  
Contact Brandi Gallaway [bgallawa@jeffco.edu](mailto:bgallawa@jeffco.edu)

# **SPORTS AT JEFFERSON COLLEGE**

## **INTERCOLLEGIATE SPORTS**

The following is a list of contact extensions; to reach the employee, dial (636) 481-XXXX.

- **Men's Baseball:** Coach – Zachary Bone, ext. 3385
- **Men's Soccer:** Coach – Leo Driscoll, ext. 3397
- **Women's Soccer:** Coach – Leo Driscoll, ext. 3397
- **Men's Basketball (beginning Fall 2023):** Coach – Cornelius Walker, ext. 3382
- **Women's Basketball:** Coach – Cornelius Walker, ext. 3382
- **Women's Softball:** Coach – Chris Starkey, ext. 3379
- **Women's Volleyball:** Coach – Aida Steiger, ext. 3390

For more information about intercollegiate sports contact the appropriate coach or Robert Deutschman, Director of Athletics, at ext. 3386 or [rdeutsc2@jeffco.edu](mailto:rdeutsc2@jeffco.edu). The general phone number for information about Athletics is ext. 3394.

## **FIELD HOUSE ACTIVITY GUIDELINES**

Anyone using the Jefferson College Field House must be a student with a current Jefferson College ID for participating in an approved activity. Memberships are available for purchase online at [www.jeffco.edu/FitnessCenter](http://www.jeffco.edu/FitnessCenter). When campus is closed, the Field House is closed.

## **GENERAL FIELD HOUSE RULES AND REGULATIONS**

- Athletic shoes must be worn at all times.
- Return all equipment to each equipment station.
- Jefferson College students with current College IDs will be admitted free to all Jefferson College regular season home athletic contests.

## **SAFETY PRECAUTIONS, PROCEDURES, AND GUIDELINES**

- Before starting any fitness program, it is best to meet basic medical requirements and have a medical checkup.
- CAUTION: If heart, circulatory, or breathing problems exist, see a physician before undertaking exercise or extending your exercise limits.
- Most experts indicate that you should exercise at least five times a week.
- Exercise should not be strenuous, unpleasant, and exhausting; it should be moderate, enjoyable, and refreshing.
- After warm-up, stretching exercises should be done slowly and carefully, allowing the muscles to relax.
- A good exercise routine should contract and stretch all the major muscle groups.
- Research indicates that working out about 30 minutes a day is recommended.
- The key to making exercise safe is to individualize the exercise program.
- Any workout should include a warm-up and cool-down phase.

## **FITNESS CENTER GUIDELINES**

- Present proper identification to Fitness Center Monitor on each visit.
- Ages 16 & up are eligible to utilize the Fitness Center with a current Jefferson College ID.
- All patrons are required to complete a consent form prior to first use.
- Additional guidelines are posted in the Fitness Center.
- Please check the [Fitness Center webpage](#) for additional information and hours of operation or changes.



# SERVICES FOR STUDENTS

## ADMISSIONS

The Admissions Office is responsible for the recruitment of prospective students and assists students in all stages of the application and acceptance process. Staff members are knowledgeable about all of the programs and services offered at Jefferson College. Admissions staff can answer questions about applying for admission, dual credit and dual enrollment, placement testing, applying for on-campus housing, touring campus, degrees and certificate programs, requirements for competitive admission programs, and so much more! Prospective students who are interested in getting started at Jefferson College can call the Admissions Office at (636) 481-3235, email [admissions@jeffco.edu](mailto:admissions@jeffco.edu), visit us on the web at [www.jeffco.edu/student-services/admissions](http://www.jeffco.edu/student-services/admissions), or sign up for a Pre-Admission Student Session (PASS) to learn more about what the College has to offer. For more information on Admissions services, please call (636) 481-3235 or email [admissions@jeffco.edu](mailto:admissions@jeffco.edu).

## ADVISING SERVICES

Advising Services utilizes a one-stop shop foundation in order to assist students with academic advising, registration, financial aid, transfer assistance, and career guidance. Pathways of interest have been developed with an Advising Specialist assigned to each pathway. Meeting with the Advising Specialist in your preferred pathway is critical to ensuring that you choose the right program for your educational and career goals. To make an appointment to speak with your Advising Specialist, use the Advisor Scheduling App on the Student tab in your MyJeffco portal. Select the pathway of your interest and follow the prompts to schedule your advising appointment. Have a quick question? Email [advisor@jeffco.edu](mailto:advisor@jeffco.edu) or call (636) 481-3209 for assistance.

## CAMPUS POLICE

Campus Police ensure a safe and secure campus environment for students, faculty, and staff. They assist the campus community with all criminal offenses, traffic safety, vehicle-related issues such as lockouts and jump starts, as well as provide safety escorts to vehicles upon request. Campus Police are available at the Hillsboro campus 24/7 and during many open hours at the Arnold location. The Jefferson College Police Department office is located in the Viking Woods Apartment complex in apartment #214.

Please call 911 in an emergency; in non-emergency situations or if you have a general question, contact the on-duty officer at (636) 481-3500.

## CARE TEAM

The Care Team at Jefferson College is a cross-functional team whose purpose is to assist in identifying, assessing, and evaluating student wellbeing and concerning student behaviors in a trauma-informed way. The Care Team designs intervention and outreach to promote individual safety, community safety, and student success to support an inclusive environment. The Care Team may also identify patterns of behavior that might suggest the need for ongoing or additional intervention. Connecting students with individualized resources, support, and accountability is at the core of Care Team interventions.

Students can self report or report concerns about other students by completing the Maxient Student Incident Report on the “Vikings Care” or “Student” tab in MyJeffco.

The Care Team meets weekly to assess incoming reports and implement appropriate intervention(s), as needed. For further information regarding the Care Team, please contact (636) 481-3262 or visit: [www.jeffco.edu/current-students/resources/care-team](http://www.jeffco.edu/current-students/resources/care-team).

## COUNSELING SERVICES

The COMTREA On-Campus Therapist, located on campus, and Central Methodist University’s Clinical Counseling Center, virtual appointments only, are both contracted to provide counseling services for Jefferson College students. Counseling services are free to any student enrolled in the semester during which they seek services. Consultation and outreach services are also available for students, faculty, and staff. To schedule an appointment, please contact:

- COMTREA’s On-Campus Therapist at (636) 481-3215/[counseling@jeffco.edu](mailto:counseling@jeffco.edu)/Student Center, Room 202. Appointments may also be made directly at: [calendly.com/hbond3](https://calendly.com/hbond3) or
- Central Methodist University’s Clinical Counseling Center at [cccjeffco@centralmethodist.edu](mailto:cccjeffco@centralmethodist.edu) for virtual appointments only.

## EARLY CHILDHOOD CENTER

The Jefferson College Early Childhood Center provides comprehensive, high quality child care/education programs for preschool and school-age children while parents pursue educational and employment goals. The Center serves as a laboratory

setting for students enrolled in early childhood or other curricula related to the care and education of children. Students are provided an opportunity to observe and interact with children in a quality early childhood education setting.

The Center is licensed by the Department of Health and Senior Services, and is accredited by Missouri Accreditation of Programs for Children and Youth.

The Center accepts enrollment of children for the following programs:

- Two year olds – ages 2 - 3 1/2
- Preschool – ages 3 1/2 through 5
- School Age – ages 6 through 12 – Before /After school and summer school-age programs
- Family Services Division – Childcare Tuition Assistance Vendor

Interested students should stop by the Center (north of the Student Services building, Hillsboro Campus) or call (636) 481-3299 for more information.

## **ENROLLMENT SERVICES**

The Enrollment Services Office is your stop for assistance at Jefferson College. Enrollment Services Assistants can answer various questions regarding registration, transcripts, and general financial aid.

Jefferson College transcripts can be ordered online 24/7 through the National Student Clearinghouse; costs and fees are applicable. Students can place as many orders as they like in one session using any major credit card. For more information, call (636) 481-3209 or visit the website at [www.jeffco.edu/current-students/admissions-enrollment/transcripts](http://www.jeffco.edu/current-students/admissions-enrollment/transcripts). For more information on Enrollment Services, please call (636) 481-3209 or email [register@jeffco.edu](mailto:register@jeffco.edu).

## **FINANCIAL AID**

The Financial Aid Office provides current and prospective students with information about funding opportunities available to assist with paying for college. Staff members can assist individuals in completing the necessary application forms for federal, state, and institutional financial aid. For more information on Financial Aid, call (636) 481-3212 or email [fnaid@jeffco.edu](mailto:fnaid@jeffco.edu).

## **RESIDENTIAL LIFE**

Viking Woods Student Housing offers students an opportunity to live just a short walk from classes and campus resources. The apartment-style facilities include full operational kitchens in addition to furnished living rooms and bedrooms. Amenities include Internet access, 24-hour computer lab, laundry facilities, volleyball court, basketball hoop, and more. For more information, contact Viking Woods at (636) 491-3294 or [vikingwoods@jeffco.edu](mailto:vikingwoods@jeffco.edu).

## **STUDENT DEVELOPMENT**

The Student Development Office provides meaningful cultural, educational, and social opportunities to complement the academic programs of Jefferson College students. These include:

- Clubs and organizations
- Leadership opportunities and training
- Volunteer opportunities in the community

Contact Brandi Gallaway [bgallawa@jeffco.edu](mailto:bgallawa@jeffco.edu) or (636) 481-3231 for more information.

## **STUDENT SUPPORT SERVICES (PROJECT SUCCESS)**

Student Support Services (Project SUCCESS) is a TRIO program funded by the U.S. Department of Education. The purpose of Project SUCCESS is to help students acquire academic and coping skills necessary to persevere and succeed in earning a four-year college degree. Project SUCCESS staff provide individualized services, including: academic advising, transfer assistance, workshops on personal and academic issues, career assessment and counseling, financial aid information, tutoring, leadership opportunities, cultural enrichment, and ongoing personal support. To qualify for Project SUCCESS, students must be at least one of the following: a first-generation college student (neither parent has earned a Bachelor's degree), income-eligible (as determined by federal guidelines), or have a documented disability. Project SUCCESS applications are available online at [www.jeffco.edu/ProjectSuccess](http://www.jeffco.edu/ProjectSuccess), in the Project SUCCESS Office located on the top floor of Student Center, Room 217, or by calling (636) 481-3281.

## VIKINGS CARE

Jefferson College and COMTREA on Campus promote student wellness, safety, and educational success. Vikings Care recognizes the challenges of being a college student and strives to provide educational opportunities to develop skills, increase help-seeking behaviors, promote safety, and encourage diversity. Through Vikings Care initiatives, the College connects students to resources that help them achieve their goals. For additional information, visit the “Vikings Care” tab in MyJeffco.

Vikings Care Days and Initiatives:

September 6, 2022: Campus Safety Awareness

October 4, 2022: Domestic Violence Awareness

November 1, 2022: Great American Smokeout

December 6, 2022: Impaired Driving Prevention

February 7, 2023: Healthy Relationships Awareness

March 7, 2023: Underage Drinking Prevention and Awareness

April 4, 2023: Sexual Assault Awareness

May 2, 2023: Mental Health Awareness

## VIOLENCE PREVENTION PROJECT

The Violence Prevention Project’s main goal is to reduce and eliminate dating violence, domestic violence, sexual assault, and stalking on campus. To learn more about how to help a friend or find more information on awareness and prevention of interpersonal violence, please contact the Project Director at [slund@jeffco.edu](mailto:slund@jeffco.edu), (636) 481-3269, or the Student Advocate at [alowery3@jeffco.edu](mailto:alowery3@jeffco.edu), (636) 481-3267. Visit our website at [www.jeffco.edu/resources/vikings-cares/victim-advocacy](http://www.jeffco.edu/resources/vikings-cares/victim-advocacy).

## WORKFORCE AND EMPLOYMENT SERVICES

The Workforce and Employment Services Office provides students and graduates with information and tools to prepare for successful job searches. Through individual assistance or workshops, the office provides advice on resume and cover letter development, interview techniques, job search strategy, Career Closet, and connections to job openings in the community. The office coordinates all non-credit workforce programming, hosts job fairs, and provides other opportunities for students to interact with potential employers, as well as collects job placement data for Associate of Applied Science and Certificate graduates. For more information on Workforce and Employment Services, call (636) 481-3144 or email [workforce@jeffco.edu](mailto:workforce@jeffco.edu).

## ACADEMIC SUPPORT SERVICES FOR STUDENTS

### ACADEMIC SUCCESS CENTER

The Academic Success Center at Jefferson College supports the educational development of students and reinforces classroom learning. The Center strives to empower students to achieve their academic goals by providing opportunities to enhance student learning and achieve course success and personal growth. The Center outcomes help meet the College’s academic success, retention, and graduation goals.

The Academic Success Center consists of the following services located in the Technology Center: Science Lab, Math Lab, Writing Lab, and Computer Information Systems Lab. These labs are staffed with professionals who have degrees and instructional experience in their respective fields; many are full-time faculty.

Academic Success Centers are a proven initiative nationally to help students meet their educational goals. Come by and learn more about the services offered. Your success is our success. The Center is open Monday-Thursday, 8 a.m. – 8 p.m., and Friday, 8 a.m. – 4 p.m. The Writing and Math Lab staff are available Monday-Friday, 8 a.m. – 3 p.m. For more information, call (636) 481-3439 or email [rstephe4@jeffco.edu](mailto:rstephe4@jeffco.edu).

### MATH LAB

The Math Labs are located in the Technology Center, Room 107, in the Academic Success Center at Jefferson College Hillsboro, and in the Academic Support Center at Jefferson College Arnold. Students who need help with courses ranging from Beginning Algebra to Differential Equations may drop in for assistance from various adjunct and full-time instructors. Math tutorial software is available on the computers in the Math Labs. The Math Lab is also available online. Go to MyJeffco, then Online Support tab. Scroll down to the Online Math Lab and follow the directions provided for accessing these services while

off campus and during evenings and weekends. The schedule for online services is posted on the Online Math Lab site.

## **WRITING LAB**

Jefferson College offers two writing lab support service options. The on-campus lab is located in the Technology Center, Room 105, as part of the Academic Success Center at the Hillsboro campus. The Writing Lab has computers with Internet access, and WiFi is also available. The Online Writing Lab (JC OWL), accessible through the Online Support tab in MyJeffco, offers paper review services, as well as live chat with tutors. In both labs, current English faculty provide assistance with creating, organizing, developing, and revising writing of all kinds. Hours for the Online Writing Lab (JC OWL) vary. Schedules for both writing labs are located online in MyJeffco.

## **SCIENCE LAB**

The Science Lab is located in the Technology Center, Room 109, in the Academic Success Center at Jefferson College Hillsboro, and in the Academic Support Center at Jefferson College Arnold. Students who need help with courses in Biology, Microbiology, Anatomy and Physiology, and Chemistry may drop in for assistance from various adjunct and full-time instructors. The Science Lab is also available online. Go to MyJeffco and the Online Support Tab. Scroll down to the Online Science Lab and follow the directions provided for accessing these services while off campus and during evenings and weekends. The schedule for online services is posted on the Online Science Lab site.

## **FOUNDATIONS LAB**

The Foundations Lab is located in the Technology Center, Room 111 (Academic Success Center), at the Hillsboro campus. Students needing tutoring in math, reading, and writing, as well as help preparing for math and reading placement examinations, can obtain assistance and instructional resources from a team of professional instructors. Additionally, the Foundations Lab holds camps in the summer for reading and math that are designed to help students prepare to take the College's math and reading placement tests.

## **DISABILITY SUPPORT SERVICES**

Jefferson College is dedicated to providing reasonable accommodations and appropriate services to students with disabilities. The Disability Support Services (DSS) Office collaborates with students, faculty, and staff to provide equal access to educational opportunities, programs, and activities.

The DSS Coordinator assists students with disabilities by working with staff and faculty to provide reasonable accommodations that allow students to demonstrate their abilities, knowledge, and skills. This is achieved while treating any disability-related information confidentially.

### **1. WHO IS ELIGIBLE?**

The DSS Office provides services for any Jefferson College student with a diagnosed disability, including but not limited to: visual, hearing, psychiatric, physical, and learning disabilities. Current and appropriate documentation of a disability must be provided to the DSS Office and must show how the disability substantially limits one or more major life activities before accommodations can be provided. To request information regarding required documentation, contact the DSS Office at Jefferson College Hillsboro, Technology Center, Room 101, (636) 481-3158. More information can be found on the Jefferson College website at [www.jeffco.edu/dss](http://www.jeffco.edu/dss).

### **DEFINITIONS**

A qualified student with a disability means any person who:

- (a) has a physical or mental impairment which substantially limits one or more major life activities, and
- (b) has documentation of such an impairment, has a history of such an impairment, or is perceived as having such an impairment.

### **GETTING STARTED...**

To ensure appropriate accommodations are in place before the semester begins, the following steps must be taken:

1. Contact Disability Support Services at (636) 481-3158 to discuss potential eligibility and the process for accessing disability services or refer to our website: [www.jeffco.edu/DSS/Getting-Started](http://www.jeffco.edu/DSS/Getting-Started).
2. Complete an [Application for Services](#).
3. Provide Disability Support Services with all requested and appropriate documentation. (Documentation criteria can be



found in the [DSS Policies and Procedures Manual](#)).

4. Meet with an Advising Specialist and register for classes.
5. Check-in with the DSS office each semester, or when updated documentation needs to be presented, to ensure access to all approved accommodations and services in a timely manner.
6. Discuss approved accommodations with assigned faculty at the beginning of each semester. **Failure to discuss accommodations with your instructor can delay or prevent use of academic accommodations.**

For more information, contact the Disability Support Services Office at (636) 481-3158 or email [dss@jeffco.edu](mailto:dss@jeffco.edu).

## TESTING SERVICES

Testing Services offer a variety of services for students including placement testing, distance learning tests, exit exams (graduation requirement), faculty make-up tests, and many other standardized tests (ACT, CLEP, WorkKeys, HESI A2 for entrance into the health occupations programs, HiSET Missouri High School Equivalency, MoGEA, POST, ASE, and others). Visit the Testing Center webpage at [www.jeffco.edu/Testing-Center](http://www.jeffco.edu/Testing-Center) to learn more.

## PEER TUTORING

Peer tutoring services are available for students who need academic assistance. This program matches students one-on-one with trained tutors and is provided at no cost to the student. Stop by the Academic Success Center to sign up for peer tutoring services or sign up online in MyJeffco under the Student tab.

## LEARNING EXPRESS LIBRARY

The Learning Express Library is a comprehensive, interactive source for online tutorial courses and practice tests designed to help students and adult learners succeed on licensing and academic tests. The site offers immediate scoring, complete answer explanations, and individualized analyses of results. Included are preparation areas such as ACT, job and career testing preparation, nursing, SAT, TOEFL, U.S. citizenship, math, reading, and writing skills improvement. The Learning Express Advantage can be found [online at www.jeffco.edu](http://www.jeffco.edu) > [Academics](#) > [Academic Services](#) > [Adult Education & Literacy](#) > [Student Resources](#), and then select [Learning Express Library](#).

## LIBRARY SERVICES

Jefferson College Library provides research and technology help, articles and books for assignments, and spaces for individual and group study. Librarians teach information literacy and critical research skills to individuals and classes. The Library offers popular reading materials, DVDs, streaming videos, CDs, telescopes, board games, and other fun items for check-out.

Panel discussions, guest speakers, displays, musical events, de-stressing activities, and other events are offered throughout the year.

### HILLSBORO

The Library reopened in March 2018 after a complete renovation of the 1966 structure. Computers, SMARTboards for student use, group and individual study spaces, over 300 places to plug-in, and abundant natural light are just a few of the features.

- [Ask-A-Librarian](#) links to [chat](#), email, text, and phone help, including after-hours assistance from librarians.
- [LibGuides](#) are research guides to help students navigate the sources they need to use for college-level assignments.
- Drop-in help with research is available whenever the Library is open and by appointment. Email staff at [refdesk@jeffco.edu](mailto:refdesk@jeffco.edu) or call (636) 481-3166.
- Thousands of articles may be accessed on and off-campus by using the [Library's databases](#).
- Streaming video, audio books, and eBooks [are available](#) for school work and fun.
- Study spaces may be booked by students up to 30 days in advance using [LibCal](#).

The Library also offers the following:

- Meeting rooms for student clubs and large study groups
- Laptops, Chromebooks, and tablets for check-out
- Content Creation Lab, Adobe Creative Suite, equipment, and green screen for video and audio creations
- Over 60,000 print volumes can be found in our catalog, Archway, and access to millions more is available in the MOBIUS catalog with free delivery to all campuses.
- Jefferson County History Center & Archives
- Federal Depository Library collection with government information sources

## **ARNOLD/IMPERIAL**

- [Ask-A-Librarian](#) links to [chat](#), email, text, and phone help, including after-hours assistance from librarians.
- [LibGuides](#) are research guides to help students navigate the sources they need to use for college-level assignments.
- Thousands of articles may be accessed on and off-campus by using the [Library's databases](#).
- Streaming video, audio books, and eBooks [are available](#) for school work and fun.
- Deliveries of library materials are available to JCA and JCI via campus courier.
- MOBIUS pick-ups are available at JCA and JCI locations and college libraries throughout the state via Pick-Up-Anywhere.

Call (636) 481-3166 or email [refdesk@jeffco.edu](mailto:refdesk@jeffco.edu) to get help with research or requesting library materials. Visit our [Hours](#) page, [Ask-A-Librarian](#), or [jeffco.edu/library](http://jeffco.edu/library) for additional information.

## **ONLINE COURSES**

Jefferson College offers an extensive number of courses that take advantage of the Internet to distribute materials, communicate with students, and provide a rich, interactive learning environment. Some degrees are also offered fully online. Online courses are often taken by students to help them balance their changing schedule or personal responsibilities. For more information on online courses, visit [www.jeffco.edu/JCOnline](http://www.jeffco.edu/JCOnline).

## **STUDENT CODE OF CONDUCT**

### **Student Conduct Defined**

The College recognizes that students are both citizens and members of the academic community. As citizens, students enjoy the same freedoms and rights that all citizens enjoy --freedom of speech and assembly, freedom of association, freedom of the press, right of petition, and right of due process. As members of the academic community, students are expected to conduct their affairs in accordance with the standards set forth in this Student Code of Conduct. Because the College must maintain its credibility as an institution of higher education, it has established and maintains standards of academic honesty against which students are regularly evaluated in the performance of their course work.

Upon enrolling in the College, each student assumes an obligation to conduct themselves in a manner compatible with the College's function as an educational institution and to comply with the laws enacted by Federal, State, and local governments. If this obligation is neglected or ignored by the student, the College must, in the interest of fulfilling its function, institute appropriate disciplinary action. Examples of misconduct which may be subject to disciplinary action, including disciplinary probation, suspension, and expulsion are as follows:

### **Examples of Misconduct**

#### **1. Academic Dishonesty**

**Plagiarism** – The unauthorized use of materials not written or created by the person claiming authorship. Plagiarism includes but is not limited to the following:

- a. Turning in a written essay produced by someone else.
- b. Collaborating on a written assignment without the specific approval of the instructor.
- c. Borrowing materials from any source--professional or amateur--and turning them in as original.
- d. Failure to acknowledge through appropriate citations any words, ideas, research, graphics, etc. produced by someone other than the person claiming authorship.

**Cheating** – Dishonest acts committed while being tested or evaluated. Cheating includes but is not limited to the following:

- a. Copying from another person's tests or assignments.
- b. Using unauthorized test aids such as notes, drawings, books, etc., during an examination.
- c. Submitting a paper which was turned in to another instructor in another class to fulfill part of that course's required work--unless agreed upon ahead of time by the instructor of the second course.
- d. Aiding another student in dishonesty, such as producing written work or sharing information during a test period.
- e. Fabricating research or source materials.
- f. Stealing, buying, or somehow obtaining a test from an instructor's work area or computer files.

## **2. Interference with the Educational Mission of the College**

**Sabotage** – Interference with or destruction of the work or property of another person, including the misuse of computers.

Sabotage includes but is not limited to the following:

- a. Forgery, alteration, or misuse of College documents, records, or identification.
- b. Use, possession, or distribution of alcohol, narcotics, or dangerous drugs except as permitted by law and College regulations.
- c. Obstruction or disruption of teaching, research, administration, disciplinary procedures, or other College activities, including its public service functions, or of other authorized activities on College premises.
- d. Theft or damage to property of the College or of a member of the College faculty, of a College student, or of a campus visitor.
- e. Unauthorized entry to or use of College facilities.
- f. Knowingly furnishing false information to the College.
- g. Conduct which adversely affects the student's ability to function as a member of the academic community.
- h. Misuse of computers including but not limited to:
  - 1) Unauthorized entry into a file to use, read, or alter it
  - 2) Unauthorized transfer of a file
  - 3) Downloading licensed software
  - 4) Abuse of computer time
  - 5) Infecting computers with a virus.

## **3. Behavioral Misconduct**

**Misconduct** – Violation of College rules/policies or State/Federal laws. Behavioral misconduct includes but is not limited to:

- a. Failure to identify one's self when requested by College officials or failure to comply with directions of College officials acting in the performance of their duties.
- b. Physical abuse, harassment including sexual harassment, or conduct by any student at College sponsored or supervised functions, which threatens or endangers the health and safety of any person or creates a hostile or offensive educational environment for any person. Students who believe themselves victims of harassment or discrimination, including but not limited to sexual harassment or sexual assault, should refer to Board Procedure VII-012 Complaints Alleging Discrimination or Harassment Based on Age, Ancestry, Color, Creed, Disability, Genetic Information, Marital Status, National Origin, Race, Religion, Gender Identity or Expression, Sexual Orientation, or Veteran Status, as well as Discrimination on the Basis of Sex and/or Board Procedure VII-012.1 Jefferson College Title IX Sexual Harassment Procedure and Grievance Process.
- c. Disorderly or immoral conduct or expression, breach of the peace and aiding or inciting another to breach the peace, or infringement upon the rights of others either on College-owned property or at College-sponsored or supervised functions.
- d. Possession or use of firearms, explosives, dangerous chemicals, or other weapons on College-owned or controlled property or at College-sponsored functions, except as permitted by law and College regulations.
- e. Dressing or personally appearing in a manner which unduly disturbs a classroom, instructional activity, or other College activity.

# **RULES OF PROCEDURE FOR VIOLATIONS OF THE STUDENT CODE OF CONDUCT**

## **1. Preamble**

The following Rules of Procedure shall be followed in any disciplinary proceedings for violations of the Student Code of Conduct. These Rules of Procedure are intended to ensure that appropriate due process is provided in student disciplinary proceedings and to provide clear procedures for these proceedings. The application of these procedures does not imply or create immunity from civil or criminal proceedings.

## **2. Definitions**

As used in these rules, the following definitions shall apply:

**Conduct Officer:** For purposes of informal dispositions of disciplinary matters, the term Conduct Officer shall mean the Student Conduct and Care Team Coordinator or their designee.

Director of Student Compliance: For the purposes of formal disposition of disciplinary matters, the term Director of Student Compliance shall mean the Director of Student Compliance or their designee.

Appeal: The exercise of the right to appeal by the student or Conduct Officer where discipline of suspension or expulsion is imposed.

Reprimand and Warning: A student may be given a reprimand accompanied by a written warning that the student may receive additional sanctions if the student engages in the same misconduct again or commits any other violation of this code.

Disciplinary Probation: After a finding of violation of the Student Code of Conduct, restriction of student's privileges for a designated period of time and includes the probability of more severe disciplinary sanctions if the student is found to be violating any College regulations during the probationary period. As a condition of probation, the student may be required to participate in a specific program, such as a counseling program, an educational session or project, or write a position paper on a topic related to the violation.

Disciplinary Suspension: An involuntary separation of the student from the institution for misconduct apart from academic performance for a specified period of time. Suspension differs from expulsion in that after the stated time period, the student is eligible to be readmitted.

Disciplinary Expulsion: Permanent dismissal for disciplinary reasons.

Other Disciplinary Sanction: Restitution, restriction, denial of privilege, assignment to perform services for the benefit of the College or community; or other sanction that does not result in the student being denied the right to attend classes.

Review: The exercise of the right of the student or Conduct Officer to request review by the Vice President of Student Services, whether or not discipline is imposed and when the discipline imposed is other than suspension or expulsion.

Student: A person currently enrolled in the College or one who was enrolled at the time of the alleged infraction. For the purpose of these rules, student status continues whether or not the College's academic programs are in session. A person not falling within the definition of a student may not be entitled to the benefits of these procedures but shall be subject to prosecution by civil authority for illegal actions.

### **3. Rules of Procedure**

#### **Section 1. Initiation of Disciplinary Proceedings**

Any employee or any student of the College may request initiation of disciplinary procedures against any student suspected of violation of Board policies or College regulations.

#### **Section 2. Designation of College Official for Administration of Discipline**

The Student Conduct and Care Team Coordinator is the primary officer for administration of discipline for unacceptable conduct or for conduct which involves infraction of College rules and regulation, and they will initiate disciplinary action in accordance with these regulations.

#### **Section 3. Preliminary Procedures**

Disciplinary proceedings are not to be construed as judicial trials, but care shall be taken to comply as fully as possible with the spirit and intent of the procedural safeguards set forth herein.

The appropriate Conduct Officer shall investigate any reported student misconduct before initiating disciplinary procedures and give the student the opportunity to present their personal version of the incident or occurrence. The Conduct Officer may discuss, consult, and advise with any student whose conduct is called into question. The student shall attend such consultations as requested and shall be given a copy of these Rules of Procedure. The Conduct Officer, in making the investigation and disposition, may utilize students, faculty, staff, or administrators to make recommendations which shall be considered in carrying out the authority granted under the Conduct Officer. Any written correspondence between the Conduct Officer and the student that is not hand delivered to the student by the Conduct Officer shall be sent to their jeffco.edu account or sent certified, return receipt requested.



#### **Section 4. Informal Disposition**

The Conduct Officer, after investigation, shall have the authority to impose appropriate discipline. The Conduct Officer shall fix a reasonable time (such as five {5} business days) within which the student shall either accept or reject such proposed disposition. Failure of the student to respond in writing within the time fixed shall be deemed to be an acceptance, and in such event, the proposed disposition shall become final upon expiration of such time. Where the disposition proposed in the preliminary proceeding is not accepted by the student in writing, the matter shall be referred to formal disposition for resolution. The Conduct Officer, at their discretion, may refer cases to formal disposition without first offering informal disposition.

#### **Section 5. Temporary Removal from a Facility**

The supervisor of an educational or service area may at any time suspend or remove a student from the supervisor's assigned area of responsibility pending informal or formal procedures when they find and believe from information coming to their attention that the presence of a student in that area is seriously disruptive or there is reason to believe that the student is in violation of the Code and the student's continued presence will constitute further violation. Such summary removal shall not exceed a period of five (5) business days, unless within such time the College has commenced disciplinary procedure and diligently pursues each procedure to its conclusion, in which event such summary removal may be continued until such conclusion.

#### **Section 6. Temporary Suspension**

The President or any Conduct Officer may at any time suspend or deny re-admission to a student from the College pending formal procedures when they find and believe from information coming to their attention that the presence of a student on campus would seriously disrupt the operation of the College or constitute a danger to the records or other physical properties of the College or to the health, safety, or welfare of the student or other persons. Such summary suspension shall not exceed a period of five (5) business days, unless within such time the College has commenced formal disciplinary procedure and diligently pursues each procedure to its conclusion, in which event such summary suspension may be continued until such conclusion.

#### **Section 7. Formal Disposition**

a. General Statement of Procedures: A student charged with a breach of College rules or regulations or conduct in violation of the Student Code of Conduct is entitled to a written notice of the alleged violation(s), its source in College policy, and a formal conference unless the matter is disposed of under the rules for informal disposition. The procedures set forth below shall be interpreted and administered to accomplish this objective and provide for prompt consideration and disposition of student conduct cases.

b. Notice of Alleged Violation(s): The Conduct Officer shall initiate disciplinary actions by arranging with the Director of Student Compliance to call a formal conference and by giving written notice by jeffco.edu email, certified mail, or personal delivery to the student charged with misconduct, which shall set forth the date, time, and place of the alleged violation; the conduct to be inquired into; and the date, time, and place of formal conference before the Director of Student Compliance. Notice by certified mail may be addressed to the last address currently on record with the College. Failure by the student to have their current correct local address on record with the College shall not be construed to invalidate such notice.

c. Rules for Formal Disposition: The Director of Student Compliance shall have the right:

- 1) In cases involving more than one student which arise out of the same transaction or occurrence, to hear such cases together (in that event, separate findings and determinations for each student shall be made).
- 2) To permit a stipulation of facts by the Conduct Officer and the student involved.
- 3) To permit the incorporation in the record by a reference of any document, affidavit, or other thing produced and desired to be incorporated in the record by the College or the student charged.
- 4) To question witnesses or other evidence introduced by either the College or the student at any time.
- 5) To hear from the Conduct Officer about dispositions made in similar cases and any dispositions offered to the student.
- 6) Add additional witnesses or require additional investigation.

7) To dismiss any action at any time or permit informal disposition as otherwise provided.

8) To at any time permit or require amendment of the Notice of Alleged Violation(s) to include new or additional matters which may come to the attention of the Director of Student Compliance before final determination of the case, provided, however, that in such event the Director of Student Compliance shall grant to the student or Conduct Officer such time as the Director of Student Compliance may determine reasonable under the circumstances to answer or explain such additional matters

d. Student Rights Upon Formal Conference.

1) To make any statement to the Director of Student Compliance in mitigation or explanation of the conduct in question that the student desires.

2) To have an advisor of their choice appear with them and to consult with such advisor during the conference.

3) To hear or examine evidence presented to the Director of Student Compliance against them at the conference.

4) To present evidence by witness or affidavit of any defense the student desires.

5) To be informed in writing of the findings of the Director of Student Compliance and any discipline they impose.

6) To appeal to the Vice President of Student Services or President as herein provided.

e. Determination by Director of Student Compliance: The Director of Student Compliance will examine the documentation relating to the matter-meaning the allegation(s), investigative materials, and formal conference information and make a determination within five (5) business days after submission of the documentation and conclusion of any and all conferences. The Director of Student Compliance may, in their sole judgement and discretion, contact any individual to seek additional information if they deem such information necessary to reach a decision. The Director of Student Compliance shall then make their findings and determination. Separate findings are to be made:

1) As to the conduct of the student.

2) On the discipline, if any, to be imposed.

No discipline shall be imposed on the student unless the Director of Student Compliance is reasonably convinced by the evidence that the student has committed the violation charged and should be therefore disciplined.

**Section 8. Record of the Case**

The record of the case shall be maintained and kept as long as the discipline imposed shall be in force, or for seven (7) years. The notice, exhibits, record, and the findings and determination shall become the "Record of the Case" and shall be filed in the Student Conduct and Care Team Office and, for the purpose of appeal, be accessible at reasonable times and places to both the College and the student.

**Section 9. Right of Appeal**

a. When a student is suspended, expelled, or dismissed, the Conduct Officer or the student may appeal such decision to the Vice President of Student Services by filing written notice of appeal with the Vice President of Student Services within ten (10) consecutive calendar days after notification of the decision of the formal disposition. A copy of the Notice of Appeal will be simultaneously given by the student to the Conduct Officer or by the Conduct Officer to the student. The appealing party may file a written memorandum for consideration by the Vice President of Student Services with the Notice of Appeal, and the Vice President of Student Services may request a reply to such memorandum by the student or the Conduct Officer.

b. The Vice President of Student Services shall review the full record of the case and the appeal documents and may affirm, reverse, or remand the case for further proceedings and shall notify the Conduct Officer, Director of Student Compliance, and the student, in writing, of the decision on the appeal.

c. The Conduct Officer or the student may thereafter appeal to the President of Jefferson College by filing a written Notice of Appeal with the President of the College and giving notice to either the student or the Conduct Officer, as appropriate. Such Notice of Appeal must be filed within ten (10) consecutive calendar days of the notification of action by the Vice President of Student Services.

d. The appealing party may file a written memorandum for consideration by the President with the Notice of Appeal and the President may request a reply to such memorandum by the student or the Vice President of Student Services.

e. The President shall take such action on the appeal as they deem appropriate. The President shall notify the student, the Conduct Officer, Director of Student Compliance, and the Vice President of Student Services in writing of their decision.

### **Section 10. Right to Petition for Review**

a. In all cases where the discipline imposed through formal disposition is other than suspension or expulsion, the Conduct Officer or the student may petition the Vice President of Student Services in writing for a review of the decision within five (5) consecutive calendar days after the notification of the decision of the Director of Student Compliance and by serving a copy of the Petition for Review upon the non-appealing party within such time. The Petition for Review shall cite the ground or reasons for review, and the non-appealing party may answer the petition within five (5) consecutive calendar days if they so desire.

b. The Vice President of Student Services may grant or refuse the right of review. If the Vice President of Student Services reviews the decision, the action of the Vice President of Student Services shall be final unless the decision is to refer the matter for further proceedings.

### **Section 11. Status During Appeal**

In cases of suspension or expulsion where a Notice of Appeal is filed within the required time, a student may petition the appellate authority in writing for permission to attend classes pending final determination of the appeal. The appellate authority may permit a student to continue in school under such conditions as may be designated pending completion of appellate procedures provided such continuance shall not seriously disrupt the College or constitute a danger to the health, safety, or welfare of the College community. In such event, however, any final disciplinary action imposed shall be effective from the date of the action of the formal disposition.

### **Section 12. Notification of a Victim**

a. A person who is a victim of any misconduct for which disciplinary proceedings are conducted under this code is entitled to participate in all proceedings.

b. If the subject matter of the disciplinary proceeding involves a crime(s) of violence and/or sex offense(s) and the accused is found responsible, the Conduct Officer is required to notify the victim of the outcome of the disciplinary proceedings within five (5) business days after the proceedings have been concluded.

c. If the student(s) against whom a sanction(s) is rendered discusses the disciplinary process, or the outcome of the disciplinary process, in a public forum, any claim to confidentiality is waived.

## **RECOMMENDED PROCEDURES SURVIVORS SHOULD FOLLOW IN THE CASE OF ALLEGED DATING VIOLENCE, DOMESTIC VIOLENCE, SEXUAL ASSAULT, OR STALKING**

Dating violence, domestic violence, sexual assault, and stalking are significant experiences and can be traumatizing. Dating violence, domestic violence, sexual assault, and stalking (as defined in Board Procedure VII-012.1 Title IX Sexual Harassment Procedure and Grievance Process) can also be a violation of College policies and a violation of the law. Though each survivor's experience is unique, there are a wide range of emotions that may be felt over the days, weeks, months, and even years following a traumatic experience. These reactions may change over time, and it may be helpful to address the experience with the assistance of others. Numerous options are available for students to receive support at Jefferson College and in the community.

The purpose of this protocol is to outline the recommended procedures a student should follow if a crime of dating violence, domestic violence, sexual assault, or stalking has occurred, including:

- A. The importance of preserving evidence that may assist in proving that the alleged criminal offense occurred or may be helpful in obtaining a protection order;
- B. How and to whom the alleged offense should be reported;
- C. Options about the involvement of law enforcement and campus authorities, including the student's option to:

1. Notify proper law enforcement authorities, including on-campus and local police;
  2. Be assisted by campus authorities in notifying law enforcement authorities if the student so chooses; and
  3. Decline to notify such authorities if the student so chooses; and
- D. Where applicable, the rights of the student and Jefferson College’s responsibilities for orders of protection, “no-contact” orders, restraining orders, or similar lawful orders issued by a criminal, civil, or tribal court, or by the institution.

**Options for Seeking Assistance:** There is no one correct response - simply different options to access support and different reporting options. A survivor’s immediate and long-term safety is what is most important. The resources and options outlined in this protocol and related protocols (procedures) may be helpful to a survivor when deciding what next steps are a good fit for them.

- 1. Safety First:** Safety may look different for each person. If you are in immediate danger or seriously injured, consider calling 9-1-1. Although it may not be easy, keep the following points in mind:
- Your safety is important. If you are not feeling safe, consider reaching out to someone you trust for support.
  - What happened was not your fault. Something happened to you that you didn’t want to happen and that is NOT okay.
  - You can get help at a pace that makes you comfortable.
    - a. Safety Plan: A safety plan can help you anticipate the potential risks before or after victimization. To create a safety plan, please consider following these steps:
      - i. Identify safe friends and safe places;
      - ii. Identify the essential items you will need to take to leave the place of danger;
      - iii. Consider creating a change in your routine;
      - iv. Keep gas in your vehicle; and
      - v. Stay aware of your surroundings.
    - b. For online safety planning assistance, the myPlan app is available for download or you can visit [www.myplanapp.org/](http://www.myplanapp.org/).

2. The College encourages any student who has experienced dating violence, domestic violence, sexual assault, or stalking to talk to somebody about what happened – so they can get the support they need, and so law enforcement and the College can respond appropriately. You have several options when seeking assistance, and Jefferson College will comply with your request for assistance in notifying authorities, including:
- The option to notify law enforcement authorities about the offense;
  - The option to be assisted by campus authorities in notifying law enforcement if the victim chooses to do so; and
  - The option to decline to notify such authorities.

**a. Medical Attention and Evidence Preservation:** Consider obtaining medical treatment as soon as possible. You can receive medical attention at any medical facility; however, certain facilities have specially-trained staff to help survivors and/or have the ability to offer a sexual assault forensic exam (SAFE). Completing a forensic examination will not require you to file a police report. In Missouri, evidence may be collected even if you choose not to make a report to law enforcement. Completing an exam does help preserve evidence in case you decide at a later date to file a police report. Medical exams can also address other physical needs or trauma and access for sexually transmitted infections or pregnancy.

**i. The following medical facility has specially-trained Sexual Assault Nurse Examiners (SANE):**

SSM St. Louis University Hospital  
 (314) 257-1320  
 1202 South Grand Boulevard, St. Louis, MO 63110

**ii. The following locations offer Sexual Assault Forensic Examinations (SAFE), although they may or may not be administered by a SANE nurse.**

Mercy Hospital Jefferson  
 (636) 933-1000  
 1400 US-61, Festus, MO 63028

Mercy Hospital South  
 (314) 525-1000  
 10010 Kennerly Road, St. Louis, MO 63128



**iii. The Missouri Sexual Assault Survivors' Bill of Rights, found in section 595.201 of the Missouri Revised Statutes and at [dps.mo.gov/dir/programs/cvsu/victim-rights.php](https://dps.mo.gov/dir/programs/cvsu/victim-rights.php), provides, in part, that before, during, and after a forensic examination, a survivor has a right:**

1. To consult with an advocate before and during a forensic examination.
2. To have a support person of your choice present.
3. To delay the exam if a victim advocate cannot arrive soon, and to be informed of what it means to delay the exam.
4. To receive an examination at no charge, paid for by the Missouri Department of Public Safety.
5. To shower at no cost after an examination, unless showering facilities are not reasonably available.
6. To prompt analysis of sexual assault forensic evidence.
7. Evidence collected from your forensic sexual assault examination shall not be used to prosecute you for misdemeanor crimes or search for further evidence of any unrelated misdemeanor crimes, including misdemeanor drug offenses under chapter 579 of the Missouri Revised Statutes.
8. To be informed, upon your request, of the results of the analysis of your sexual assault forensic evidence. You may receive this information through a secure and confidential message in writing from the crime laboratory.

**b. Evidence Preservation:** It is important to preserve evidence that may be useful in proving that a crime occurred, even if you do not want to complete a medical exam. This will be helpful in obtaining a protection order or in proceeding with a criminal investigation or a campus disciplinary process should you choose to pursue any of these options.

- i. Time is a critical factor for evidence collection and preservation. As time passes, evidence may dissipate or become lost or unavailable, thereby making an investigation, possible prosecution, disciplinary proceedings, or obtaining a protection order related to the incident more difficult.
- ii. Evidence may be collected from the scene and may also be collected from the survivor's body, clothes, and other personal belongings. It is important that a survivor of sexual assault not bathe, douche, smoke, change clothing, or clean the bed/linen/area where they were assaulted if the offense occurred within the past 72 hours, to preserve evidence that may be necessary as to the proof of criminal activity. There are times that this evidence can still be collected after 72 hours, depending on the evidence.
- iii. In cases of dating violence, domestic violence, sexual assault, or stalking, survivors are also encouraged to preserve evidence that would be useful to College investigators or police by saving the following, if available:
  1. Text or instant messages
  2. Social networking pages
  3. Any other virtual or written communication
  4. Pictures, logs, or other copies of documents

**c. Reporting to Law Enforcement:** Any police department will be able to help you preserve evidence through documenting the evidence in a police report.

- i. If the crime occurred on campus, the Jefferson College Police Department (JCPD) can assist you with evidence collection. The JCPD may also seek assistance from the Jefferson County Sheriff's Office.

**Jefferson College Police Department (JCPD)**

9-1-1 or (636) 481-3500

Hillsboro-Viking Woods, 802 Mel Carnahan Drive, Apartment 214, Hillsboro, MO;

Arnold-1687 Missouri State Road, Arnold, MO;

Imperial-4400 Jeffco Boulevard, Arnold, MO

- ii. If the crime occurred off-campus, the JCPD recommends that you contact the police department where you live or where the assault occurred. Local police departments include, but are not limited to:

Hillsboro Police Department

(636) 797-3334

101 Main Street, Hillsboro, MO 63050

Arnold Police Department

(636) 296-3204

2101 Jeffco Boulevard, Arnold, MO 63010

- iii. The Missouri Sexual Assault Survivors' Bill of Rights, found in section 595.201 of the Missouri Revised Statutes and at [dps.mo.gov/dir/programs/cvsu/victim-rights.php](https://dps.mo.gov/dir/programs/cvsu/victim-rights.php), provides, in part, that before, during, and after an interview with law enforcement, a survivor has a right:
1. To consult with an employee or volunteer of a crisis center (sometimes called an "advocate") during any interview by a law enforcement official, prosecutor, or defense attorney, unless this person cannot arrive promptly. The interviewer will contact the advocate for you before starting the interview.
  2. To have your lawyer present during an interview by a law enforcement officer.
  3. To have a support person of your choice present during any interview by a law enforcement officer, prosecutor, or defense attorney. If the interviewer determines that having the support person present would hurt the interviewer, the support person may be asked to leave.
  4. To be interviewed by a law enforcement officer of the gender of your choice. If a law enforcement officer of that gender is not reasonably available, you may not be interviewed by an available law enforcement officer unless you agree.
- iv. Filing a police report will not obligate you to prosecute, nor will it subject you to scrutiny or judgmental opinions from officers. Filing a police report will:
1. Ensure that a survivor of dating violence, domestic violence, sexual assault, or stalking receives the necessary medical treatment and tests, at no expense to the victim.
  2. Provide the opportunity for collection of evidence helpful in prosecution, which cannot be obtained later.
  3. Ensure that the survivor has access to free confidential counseling from counselors specifically trained in the area of crisis intervention.
  4. Ensure that the survivor has access to information to obtain or enforce an institutional no contact directive or no trespass directive or civil order of protection, as issued by the court.
- v. If you choose to speak with law enforcement, you should expect to have privacy, that it may take a while, and that you can take a break. If you do not feel you are being taken seriously, or feel uncomfortable, you can ask to speak with the officer's supervisor or next-highest ranking officer. You will be asked to tell your story and/or write out a statement. This can feel uncomfortable or intrusive. You may also be asked the same questions more than once. It is not because they do not trust you—after a trauma, it can be difficult to describe the details. Repeating a question or asking in a different way may prompt you to remember something you forgot the first time. It can be helpful and comforting to have support when communicating with law enforcement. This can be an advocate or someone you trust. However, there may be times when law enforcement may want to speak with you privately. (Adapted from RAINN.org)
- vi. When the JCPD takes a report, they may need to speak with the accused individual to investigate the reported crime and/or determine whether or not there is an immediate threat to the physical health or safety of any student, employee, or other individual. The JCPD will inform you if this will occur.

**d. Disclosure to Jefferson College:** A disclosure is when you tell someone about the experience or incident, but not necessarily for the purposes of officially reporting the incident to the police, to the College, or for criminal, civil, or disciplinary action. It is okay to tell someone because you need someone to talk to or because you want help finding services.

**i. Student Advocate:** The Student Advocate has been specially trained to explain the options that are available to you and assist you in making the decision that is best for you, whether the alleged offense occurred on or off campus. The Student Advocate is exempt from putting the College on notice of sexual harassment, inclusive of dating violence, domestic violence, sexual assault, or stalking, via making a report to the Title IX Coordinator, but is required to report statistical information regarding any reported crime that occurs in the college setting.

Alexis Lowery  
(636) 481-3267/[alowery3@jeffco.edu](mailto:alowery3@jeffco.edu)  
Jefferson College Hillsboro, Student Center, Room 207

**ii. Jefferson College's Counseling Services:** The COMTREA On-Campus Therapist and Central Methodist University's Clinical Counseling Center are both contracted to provide counseling services for Jefferson College students and are exempt from reporting requirements. These individuals can provide you with confidentiality.

COMTREA's On-Campus Therapist  
Heather Bond  
(636) 481-3215/[counseling@jeffco.edu](mailto:counseling@jeffco.edu)  
Jefferson College Hillsboro, Student Center, Room 202  
Appointments may be made directly at: [calendly.com/hbond3](https://calendly.com/hbond3)

Central Methodist University's Clinical Counseling Center  
[cccjeffco@centralmethodist.edu](mailto:cccjeffco@centralmethodist.edu)  
Virtual Appointments Only

**iii. Jefferson College Employee:** Although many people at Jefferson College may be available to support you through this time, it is important to know that all employees of Jefferson College, excluding the Student Advocate and Counseling Services, are required to report violations of College policy to the Title IX Coordinator.

**iv. Community Resources:** These community resources may also be able to help you if you have experienced dating violence, domestic violence, sexual assault, or stalking and would like to talk about your options.

1. A statewide victim services directory is available at: [dps.mo.gov/dir/programs/cvsu/victimservices/](https://dps.mo.gov/dir/programs/cvsu/victimservices/)
2. Domestic Violence (also includes sexual assault and stalking) and the Law-A Practical Guide for Survivors is available at: [missourilawyershelp.org/wp-content/uploads/2021/06/DVandtheLaw\\_MOBarHandbook\\_FINAL\\_092019\\_web-1.pdf](https://missourilawyershelp.org/wp-content/uploads/2021/06/DVandtheLaw_MOBarHandbook_FINAL_092019_web-1.pdf)
3. COMTREA's A Safe Place - Domestic Violence Shelter-24/7 Hotline for all Sexual & Interpersonal Violence Crimes: (636) 232-2301 or (877) 266-8732
4. Mary Daniels Foundation - Domestic Violence Advocacy-8:00 a.m.-4:00 p.m., some evenings: (636) 253-3396
5. Jefferson County Sheriff's Office Victim Services Coordinator: (636) 797-5017 or [pshort@jeffcomo.org](mailto:pshort@jeffcomo.org)
6. ALIVE - Domestic Violence Prevention Agency-24/7 Crisis Line for All Sexual & Interpersonal Violence Crimes: (636) 933-2777
7. Safe Connections - Domestic & Sexual Violence Crisis Intervention & Prevention Agency: (314) 531-2003
8. Legal Services of Eastern Missouri - Civil Legal Assistance: (314) 534-4200, (800) 444-0514, 4232 Forest Park Avenue, St. Louis, MO 63108
9. National Domestic Violence Hotline: (800) 799-SAFE (7233)
10. National Sexual Assault Hotline: (800) 656-HOPE (4673)
11. National Human Trafficking Hotline: (800) 373-7888
12. Victim Connect Resource Center-Stalking Victim Assistance: 8:00 a.m.-4:00 p.m. Telephone or text: (855) 484-2846

**e. Making a Report to Jefferson College:** Making a report with Jefferson College is when you tell a Jefferson College employee about what you experienced because you want the school to be aware of the incident.

i. Making a report ensures the College is put on notice of the incident and triggers the College's Dating Violence, Domestic Violence, Sexual Assault, and Stalking Response Protocol, including promptly:

1. Undertaking an individualized safety and risk analysis to determine whether or not there is an immediate threat to the physical health or safety of any student, employee, or other individual.
2. Ensuring the survivor has a written explanation of their rights and options, which includes:
  - a. The recommended procedures survivors should follow if a crime of dating violence, domestic violence, sexual assault, or stalking has occurred;
  - b. Information about how Jefferson College protects the confidentiality of victims and other necessary parties;
  - c. A complete list of existing services for survivors, including specific information about how to access or request information regarding Counseling, Health, Mental Health, Victim Advocacy, Legal Assistance, Visa and Immigration Assistance, Student Financial Aid, and other services available for survivors, both within the institution and in the community.
  - d. The College's provisions about options for, available assistance in, and how to request protective measures and accommodations; and
    - i. Protective measures and accommodations, also known as supportive measures, are non-disciplinary, non-punitive measures put in place to assist any party impacted by dating violence, domestic violence, sexual assault, or stalking, in order to restore or preserve their equal access to their educational program, educational activity, or employment. Supportive measures are provided free of cost. Supportive measures can be used by any person involved in a report.

- e. An explanation of the procedures for institutional disciplinary action.
- ii. All reports of dating violence, domestic violence, sexual assault, and stalking that take place on College-owned or controlled properties or at College-sponsored programs or events are provided to the College's Clery Compliance Coordinator (or designee) to be assessed for inclusion in daily crime statistics, timely warning reports, emergency notifications, and for potential inclusion in the College's Annual Security and Fire Safety Report.
  - 1. The survivor's personally identifying information will not be included in any publicly available recordkeeping, including Clery Act reporting and disclosures such as the Annual Security and Fire Safety Report and the daily crime log.
- iii. Reports may be made at any time within or outside College business hours by the person who experienced the unwanted contact but may also be made by any person including third parties, students, staff, faculty, parents, or community members. Reports may be made in person, verbally, by phone, in writing through mail or electronic mail, through the College's [Maxient reporting portal](#), or any other manner that delivers the information to the appropriate Coordinator at any time.

**Vice President of Student Services/Title IX Coordinator**

Dr. Kimberly Harvey-Manus  
 (636) 481-3200/[kh Harvey@jeffco.edu](mailto:kh Harvey@jeffco.edu)  
 Student Center, Room 205  
 1000 Viking Drive, Hillsboro, MO 63050

**Director of Student Compliance/Deputy Title IX Coordinator for Students**

Kristine Bogue  
 (636) 481-3258/[kboguel@jeffco.edu](mailto:kboguel@jeffco.edu)  
 Student Center, Room 209  
 1000 Viking Drive, Hillsboro, MO 63050

**Student Conduct and Care Team Coordinator**

Holli Gillam  
 (636) 481-3262/[hgillam1@jeffco.edu](mailto:hgillam1@jeffco.edu)  
 Student Center, Room 211  
 1000 Viking Drive, Hillsboro, MO 63050

**Electronic and Anonymous Report**

[cm.maxient.com/reportingform.php?JeffersonCollege&layout\\_id=2](http://cm.maxient.com/reportingform.php?JeffersonCollege&layout_id=2)

- iv. The College prohibits retaliation against individuals involved in a report.

**f. Filing a Formal Complaint:** Filing a formal complaint with Jefferson College, a statement (written or via electronic message), is when you indicate a desire that the school start a grievance or disciplinary process.

- i. The survivor/complainant can choose to initiate the formal complaint and grievance process by, in writing or via electronic message, indicating their desire to have the College investigate their report.
- ii. Where a complainant may decline to file a formal complaint, the Title IX Coordinator will assess the known circumstances of the situation and determine whether or not a formal complaint will be filed by the Title IX Coordinator themselves. In this situation, the Title IX Coordinator will contact the complainant to discuss supportive measures, the filing of a formal complaint, and the grievance process.
- iii. The Title IX Coordinator will take the complainant's wishes into account, as well as the need for campus safety when evaluating whether or not to file a formal complaint against the responding party/respondent. The College's ability to respond to the report may be limited when a survivor does not wish to proceed with the College's grievance or disciplinary process.
- iv. Both the complainant and respondent will have equal rights/access during any investigation or grievance process.

**g. Option for No Contact Orders, No Trespass Notices, Civil-Ex Partes, and Orders of Protection:** Survivors of dating violence, domestic violence, sexual assault, or stalking have a right to obtain an Order of Protection or an Institutional "no contact" or "no trespass" order.

- i. Issued by Institution:
  - 1. No Contact Order - Reciprocal, non-punitive administrative directive from the school designed to preserve access to educational and employment opportunities.



- a. Request for a No Contact Order can be made through:
    - i. Dr. Kimberly Harvey-Manus, Vice President of Student Services/Title IX Coordinator, (636) 481-3200/[kh Harvey@jeffco.edu](mailto:kh Harvey@jeffco.edu), Student Center, Room 205, 1000 Viking Drive, Hillsboro, MO 63050
    - ii. Kristine Bogue, Director of Student Compliance/Deputy Title IX Coordinator, (636) 481-3258/[kbogue1@jeffco.edu](mailto:kbogue1@jeffco.edu), Student Center, Room 209, 1000 Viking Drive, Hillsboro, MO 63050
    - iii. Holli Gillam, Student Conduct and Care Team Coordinator, (636) 481-3262/[hgillam1@jeffco.edu](mailto:hgillam1@jeffco.edu), Student Center, Room 211, 1000 Viking Drive, Hillsboro, MO 63050
  - b. A No Contact Order may be issued when:
    - i. The survivor/complainant and the responding party/respondent are both affiliated with the College (ex: student or employee);
    - ii. The College believes the responding party/respondent may pose a threat to the survivor/complainant or the campus community.
2. No Trespass Notice - A notice restricting access to College property.
- a. Requests for a No Trespass Notice can be made through the Jefferson College Police Department:

**Jefferson College Police Department (JCPD)**

9-1-1 or (636)481-3500

Hillsboro-Viking Woods, Apartment 214,  
802 Mel Carnahan Drive, Hillsboro, MO;  
Arnold-1687 Missouri State Road, Arnold, MO;  
Imperial-4400 Jeffco Boulevard, Arnold, MO

- b. The Vice President of Student Services/Title IX Coordinator, Director of Student Compliance/Deputy Title IX Coordinator, or the Student Conduct and Care Team Coordinator can assist you with contacting JCPD to request a No Trespass Notice.
  - c. A No Trespass Notice is issued when:
    - i. The responding party/respondent is not affiliated with the College (ex: student or employee);
    - ii. The responding party/respondent is on campus property without an appropriate purpose/not reasonably related to the College's educational function or an approved College-related activity; or
    - iii. The JCPD believes there is an ongoing threat and/or safety concern relating to our students, faculty, staff, and visitors.
3. Jefferson College does not issue civil orders of protection.

**ii. Lawful Orders issued by Criminal, Civil, or Tribal Court:**

1. Ex Parte/Order of Protection - Pursuant to the Missouri Domestic Violence Act, Chapter 455, RSMo, a person may seek an Order of Protection from acts, attempts, or threats to them from a family or household member or intimate partner; or from acts of stalking or sexual assault. An Ex Parte Order of Protection is a temporary emergency order. A Full Order of Protection is the longer-lasting order. A petition alleging sexual assault, domestic violence (including dating violence), or stalking must be filed in the county where the victim resides; where the alleged incident of sexual assault, domestic violence (including dating violence), or stalking occurred; or where the accused may be served. The court clerk will provide the paperwork to be filled out, which will include information about you and the other party in regards to demographics, relationships, and the abuse. Additional information about how to file for an Ex Parte Order or Full Order of Protection, please visit [www.courts.mo.gov](http://www.courts.mo.gov).

Jefferson County Courthouse  
(636) 797-5443  
300 Main Street, Hillsboro, MO 63050

**iii. Enforcement of Order of Protection:** Although Jefferson College does not issue Orders of Protection, Jefferson College will comply with and enforce any court order. The Jefferson College Police Department is responsible for enforcing any judicially-issued protective measures, such as an Ex Parte Order or a Full Order of Protection. Any person who obtains an Order of Protection should provide a copy to the Jefferson College Police Department (JCPD) and the Title IX Coordinator to ensure enforcement of the order and to develop a safety plan to reduce risk of harm while on campus or coming and going from campus.

# **COMPLAINTS ALLEGING DISCRIMINATION OR HARASSMENT PROCEDURE**

## **DEFINITIONS**

“Complaint” means an allegation of conduct or of action, policy, procedure, or practice which would constitute discrimination/harassment on the basis of one or more of the Protected Categories.

“Compliance Coordinator” means the College’s Compliance Coordinator for students. This individual is Dr. Kimberly Harvey-Manus, Vice President of Student Services, Jefferson College, 1000 Viking Drive, Hillsboro, MO 63050, (636) 481-3200, [kharvey@jeffco.edu](mailto:kharvey@jeffco.edu).

“Day” means a school day, which is a day in which school is in session.

“Discrimination/Harassment” means discrimination and/or harassment on the basis of one or more of the Protected Categories. For purposes of discrimination, the College (or its authorized employee) must be the alleged actor. For purposes of harassment, the alleged actor may be the College, an employee of the College, a student, or a visitor to the College’s facilities.

“Employee”/ “School Personnel” means, for purposes of this regulation, board members, College employees, agents, volunteers, contractors, or persons subject to the supervision and control of the College.

“Student” means a student enrolled in the College. A parent/legal guardian is permitted to make filings and take action under this policy on behalf of students under the age of eighteen (18).

“Prohibited Discrimination” means discrimination on the basis of one or more of the Protected Categories means that the College has treated a student in a discriminatory manner on the basis of one or more of the Protected Categories when compared to similarly situated students.

“Prohibited Harassment” means harassment on the basis of one or more of the Protected Categories consists of verbal or physical conduct relating to a student’s age, ancestry, color, creed, disability, genetic information, marital status, national origin, race, religion, gender identity or expression, sexual orientation, or veteran status when:

1. The harassing conduct is so severe, persistent, or pervasive that it creates an intimidating, threatening, or abusive educational environment;
  2. The harassing conduct has the power or effect of substantially or unreasonably interfering with an individual’s educational performance; or
  3. The harassing conduct otherwise substantially and adversely affects an individual’s educational opportunities.
- Examples of conduct which may lead to or constitute discrimination/harassment on the basis of one or more of the Protected Categories include the following:
- graffiti containing offensive language which is derogatory to others because of their membership in a Protected Category;
  - jokes, name-calling, or rumors based upon an individual’s membership in a Protected Category;
  - slurs, negative stereotypes, and hostile acts which are based upon another’s membership in a Protected Category (age, ancestry, color, creed, disability, genetic information, marital status, national origin, race, religion, sex, gender identity or expression, sexual orientation, or veteran status);
  - written or graphic material containing comments or stereotypes which is posted or circulated and which is aimed at degrading individuals or members of a Protected Category;
  - a physical act of aggression or assault upon another because of, or in a manner reasonably related to, such person’s membership in a Protected Category;
  - other kinds of aggressive conduct such as theft or damage to property which is motivated by a person’s membership in a Protected Category.

## **INTAKE OF COMPLAINTS**

1. Any student who believes they have been the victim of discrimination/harassment is encouraged to immediately report the alleged acts to Dr. Kimberly Harvey-Manus, Vice President of Student Services, Student Center 205, (636) 481-3200, [kharvey@jeffco.edu](mailto:kharvey@jeffco.edu).
2. To assist the College in addressing the matter promptly and thoroughly, a student reporting discrimination/harassment is encouraged to provide a written explanation that specifically details the student’s concern.

3. Before making the report, a student who believes that they have been subjected to discrimination/harassment is not required to confront the individual who is the subject of the student's concern.
4. Any College supervisor or administrator who receives a report, orally or in writing, regarding discrimination/harassment must notify the Compliance Coordinator within one (1) school day or within a reasonable time thereafter for good cause.
5. Both the complaint and respondent will have equal rights/access during any investigation or adjudication process. This will include having an individual accompany them throughout the hearing process and being informed of the outcome of the hearing, including the final determination and any sanction that is imposed against the respondent.

## **INVESTIGATION OF COMPLAINTS**

The College desires to promptly address complaints and has established a protocol for handling such complaints. This protocol sets forth specific deadlines within which various phases of the process are intended to occur. These deadlines are subject to extension by the College for good cause or if extenuating circumstances exist. Regardless, the College remains committed to a prompt investigation and resolution of submitted complaints.

1. Upon receipt of a report of discrimination/harassment, the Compliance Coordinator may choose to investigate the complaint or may, alternatively, appoint an investigator from the College to investigate the complaint.
2. The investigation shall be conducted in the manner deemed appropriate by the Compliance Coordinator. The College desires to investigate complaints in a prompt and thorough manner. The following time frames will apply:
  - a. The investigation must be commenced within two (2) school days of the Compliance Coordinator's receipt of the report of discrimination/harassment.
  - b. Absent extenuating circumstances, investigations will be completed within ten (10) school days after the investigation commences. Changes or additions to a complaint will typically require an extension of time to ensure that the complaint is properly investigated. Similarly, scheduling issues and the unavailability of witness or relevant documents may also necessitate an extension of time.
3. Investigation files shall be maintained separately from student educational files and employee personnel files.
4. Confidentiality of personally identifiable student information obtained during investigations will be maintained in accordance with federal and state law. The College desires to protect the identity of complainants for as long of a time period as it is able to do so in accordance with law.

## **RESOLUTION OF COMPLAINTS**

1. At the conclusion of the investigation, the completed investigation report shall be provided to the appropriate administrative official who is charged with making the determination with respect to the validity of the complaint. Where they deem it appropriate, the Compliance Coordinator themselves is permitted to make this determination.
2. This administrative official will review the investigation report and make a determination regarding the validity of the complaint within five (5) school days after submission of the report. This administrative official may, alternatively, determine that further investigation is necessary and, as such, refer the matter for additional investigation. When such additional investigatory steps are completed, the matter shall once again be submitted to this administrative official for decision.
3. One of the following determinations will typically be made with respect to the complaint:
  - a. unsubstantiated;
  - b. unable to substantiate OR indeterminate OR incapable of determination;
  - c. substantiated prohibited conduct (in whole or in part)
4. Regardless of the determination made with respect to the complaint, the College may take appropriate action to minimize the opportunity for future issues or concerns to arise.
5. Notification of Determination Regarding Complaint:
  - a. Within five (5) school days after the determination has been made regarding the complaint, notice of the determination will be mailed or given to the complainant.
  - b. If a complainant disagrees with the determination made regarding discrimination/harassment, the complainant may

appeal the decision to the Compliance Coordinator (or to the Board of Trustees if the Compliance Coordinator has made the determination that is being challenged.) The complainant must submit a written appeal to the Compliance Coordinator no later than five (5) school days after the notification to the complainant has occurred. The written appeal should specifically state what is being appealed, the reason for the appeal, and the action that is desired.

c. When an appeal has been made, the appeal will be processed as follows:

The appeal will be considered by one of the following:

1. If a College official other than the Compliance Coordinator made the determination, the Compliance Coordinator will review the determination within five (5) school days or within a reasonable time thereafter for good cause. If the Compliance Coordinator made the determination as to the validity of the complaint, the Compliance Coordinator will send the appeal to the Board of Trustees, which will review the determination at its next regularly scheduled meeting (or, at its option, at any meeting within thirty (30) days after the appeal is received).
  2. As an alternative, either the Compliance Coordinator or the Board of Trustees may appoint a “Determination Review Officer” to review the determination. This person will review the determination within a reasonable period after appointment but not later than thirty (30) days unless additional time is, in their judgment, necessary for a fair review.
- d. The review will examine the documentation relating to the matter - meaning the written appeal, complaint, investigation report, and determination. This provision does not grant the complainant the right to an in-person hearing or other appearance before the reviewer. The reviewer may, in the reviewer’s sole judgment and discretion, contact any individual to seek additional information if the reviewer deems such information necessary to reach a decision upon the appeal.
- e. Regardless of who reviews the matter, the complainant will be advised in writing of the outcome of the review within seven (7) school days after the completion of the review.

6. If a complaint is substantiated (in whole or in part), and the offender is a student, disciplinary and/or other remedial action will be taken in accordance with Board-established student discipline regulations and/or in accordance with federal and state law.

7. Complaints regarding employees will be resolved utilizing the following procedures: Board Procedure II-001.5, Complaints Alleging Discrimination or Harassment Based on Age, Ancestry, Color, Creed, Disability, Genetic Information, Marital Status, National Origin, Race, Religion, or Veteran Status, as well as Discrimination on the Basis of Sex and Board Procedure II-001.2 Employee Conduct.

8. The ultimate decision as to what action to take to remedy the matter is within the discretion of the College, in accordance with law. The filing of an appeal to challenge the determination does not stay or postpone the College’s ability to initiate disciplinary or remedial action.

9. There will be no retaliation against or adverse treatment of an individual who uses this procedure to resolve a concern.

## **CONSEQUENCES AND DISCIPLINE**

1. Any student who engages in discrimination/harassment while on College property or while participating in College activities, regardless of location, will be subject to disciplinary and/or remedial action. Specific disciplinary measures may be taken consistent with College student discipline rules/regulations and in accordance with the administration’s professional judgment.

2. Any student who alleges or otherwise brings a false charge of discrimination/harassment shall receive appropriate discipline. The term “false charge” means an allegation that is brought in bad faith (i.e., without the good faith belief that one has been subjected to such discrimination/harassment).

3. The effectiveness of the College’s prohibited discrimination/harassment policies and regulations are dependent upon the receipt of truthful information. Thus, students are expected to be truthful throughout the intake, investigation, and resolution process.



# JEFFERSON COLLEGE TITLE IX SEXUAL HARASSMENT PROCEDURE AND GRIEVANCE PROCESS

---

## I. OVERVIEW OF POLICY AND PROCEDURE AND THE VALUES OF JEFFERSON COLLEGE

Jefferson College is committed to fostering an inclusive environment where all individuals are respected and empowered to achieve their goals. In pursuit of the mission, vision, and values of the College, as well as to be in compliance with all applicable local, state, and federal laws, this policy prohibits any form of discrimination on the basis of sex, inclusive of Sexual Harassment. Jefferson College is committed to providing a learning, working, and living environment where all persons are able to thrive personally, academically, and professionally.

The purpose of this policy and procedure is to clearly articulate to the Jefferson College community the expectations for behavioral standards, explain commonly used terms and concepts, provide examples and descriptions of prohibited conduct, and provide detailed information regarding every part of the process used when someone makes a report or files a formal complaint under this policy. This policy and the procedures within apply to all community members, including students, faculty, staff, contractors, and visitors. Any person who has been affected by any form of Sexual Harassment, Sexual Assault, Stalking, Dating Violence, or Domestic Violence, is strongly encouraged to make a report or speak to the Title IX Coordinator to learn more about options and resources available to them.

## II. SCOPE OF POLICY AND PROCEDURE

Jefferson College does not discriminate on the basis of sex in its educational, extracurricular, athletic, other programs, or in the context of employment. Sex Discrimination and Sexual Harassment are prohibited by Title IX of the Education Amendments of 1972, stating that:

No person in the United States shall, on the basis of sex, be excluded from participation in, be denied the benefits of, or be subjected to discrimination under any education program or activity receiving Federal financial assistance.

The Office for Civil Rights (OCR) within the United States Department of Education (DOE) has promulgated regulations implementing Title IX. Sex Discrimination and Sexual Harassment are also prohibited under Title VII of the Civil Rights Act of 1964 and other applicable statutes.

Jefferson College's Sexual Harassment Policy prohibits all forms of Sexual Harassment including Sexual Assault, Stalking, Dating Violence, and Domestic Violence against any Jefferson College community members of any sex, gender, gender identity, gender expression, or sexual orientation. Further, Jefferson College recognizes the many intersecting identities that make up each individual's lived experiences, and that harassment related to factors outside of gender, gender identity/expression, or sexual orientation can occur that are related to an individual's race, color, national origin, religion, age, disability, or other statuses. Harassment and discrimination that occurs against a person based on these characteristics violates College policy and community principles, specifically the College's Non-Discrimination policy. Matters that involve allegations of gender-based discrimination and allegations of identity-based discrimination described above will be handled by the College in accordance with the Non-Discrimination Policy.

Jefferson College will respond promptly, equitably, and thoroughly to all reports of Sexual Harassment in order to eliminate the harassment, prevent its recurrence, and address the effects or impacts on any individual(s) involved. This policy provides Jefferson College community members with information to assist those who have been impacted by Sexual Harassment regardless of their status as a Complainant, Respondent, Witness, or other participant/third-party, and provides for equitable procedures for reporting, investigation, and resolution of reports.

All Jefferson College community members are responsible for their actions and conduct, and are required to follow College policies as well as local, state, and federal laws. The Jefferson College Sexual Harassment Policy applies to conduct occurring on Jefferson College owned or controlled properties, at College-sanctioned events, educational programs or activities that take place off campus, including, but not limited to, study away (that occurs within the United States), internship programs, community-engaged learning, and athletics events. For the purposes of this policy, the conduct must fall within the parameters set forth in Section IV of this policy and procedures that define sexual harassment, occur on College owned or controlled property or within the College's educational program or activity off campus, and be committed against a person in the United States who is participating in or attempting to participate in the College's educational programs or activities. Conduct that

occurs outside of these parameters may be addressed by other applicable College policies and procedures, including but not limited to, the Board of Trustees Policies and Procedures, Administrative Policies and Procedures, The Faculty Handbook, The Adjunct Faculty Handbook, Employee Handbooks, Academic program-specific Handbooks, the Student-Athlete Handbook, or Student Conduct policies and procedures. Upon receipt of a report that falls outside the scope of this Policy and Grievance Process, the Title IX Coordinator or their designee may refer the report to the appropriate College official or department to address the report.

### **III. EXPLANATIONS OF KEY TERMS AND PHRASES USED THROUGHOUT POLICY AND PROCEDURES**

**Complainant:** This term is used to describe the individual who is alleged to be the victim of conduct that could constitute sexual harassment. To initiate a formal complaint under this policy, a Complainant must be someone who is participating in or attempting to participate in the College's educational programs or activities in the United States.

**Respondent:** This term is used to describe the person who is accused of violating policies of the College, including the Sexual Harassment Policy.

**Title IX Coordinator:** An employee of the College who has been designated to oversee the processes contained in this policy and to coordinate the College's compliance with Title IX. Deputy Title IX Coordinators are employees of the College who may also receive reports of sexual harassment and will work with the Title IX Coordinator to implement reporting procedures, supportive measures, and the implementation of the grievance process as needed. Any person may report allegations of sex discrimination or sexual harassment to the Title IX Coordinator or a Deputy Title IX Coordinator.

**Prohibited Conduct:** Conduct that violates the policy and procedures of the College, specifically in this policy referring to any form of sexual harassment as described in Section IV.

**Making a report:** Any person can make a report of alleged sex discrimination or sexual harassment to the Title IX Coordinator or Deputy Title IX Coordinators. This includes the Complainant themselves, third parties, witnesses, or parents (as the law permits). Making a report is not the same thing as filing a formal complaint.

**Filing a formal complaint:** A formal complaint is a statement (written or via electronic message) from the Complainant notifying the Title IX Coordinator that they desire that the school will investigate specific allegations of sexual harassment. The only persons who are able to file a formal complaint are the Complainant themselves (who must be an active participant in the College's programs or activities or attempting to be an active participant in the College's programs or activities, including employment) or the Title IX Coordinator under specific circumstances which are described in this Policy.

**Supportive Measures:** Supportive Measures are non-disciplinary, non-punitive measures put in place to assist any party impacted by sexual harassment in order to restore or preserve their equal access to their educational program, educational activity, or employment. Supportive measures are provided free of cost and may include such things as counseling services, safety escorts, reciprocal No Contact Orders, schedule changes, or living environment changes (where applicable). A full range of Supportive Measures and resources available at the College and in the community are described within this Policy and procedures. Supportive measures can be used by any person involved in a report of Sexual Harassment regardless of whether or not a formal complaint is filed.

**Investigation:** After a formal complaint is filed, the College will investigate the allegations promptly, thoroughly, and equitably. An investigation gathers all available information about the allegations through meetings and interviews with the Complainant, Respondent, witnesses, and other parties. More information about the investigation is contained in Sections VII and VIII of this Policy and Procedures.

**Grievance Process:** The procedures used to initiate a formal complaint, investigate the complaint, and resolve the complaint using a live hearing process. The appeals process is considered the last step of the Grievance Process. The outcome becomes final when the Grievance Process has been fully concluded.

**Advisor:** Any Complainant or Respondent may have one Advisor of their choosing present with them at any meeting or hearing as part of these procedures. Advisors may be a member of the College community, an attorney (hired at the Complainant or Respondent's expense), or any other person that the Complainant or Respondent chooses to support them through these processes. Advisors are expected to conduct cross-examination at the live hearing. Any Complainant or Respondent who does not have an Advisor at the time of the hearing will be assigned an Advisor by the College.

Standard of Evidence/Information: In resolving matters of Sexual Harassment, the standard used to determine responsibility is the preponderance of the evidence standard, meaning “is it more likely than not” that the conduct occurred or that College policies were violated. No person shall be found Responsible or Not Responsible based solely on the role that they have in the process, and Respondents are presumed to be Not Responsible until such time that there is a finding of Responsibility through the Grievance Process described herein.

Remedies: Remedies are measures designed to restore or preserve a Complainant’s access to education or employment activities under this Policy when a Respondent has been found Responsible through a Grievance Process.

Retaliation: Retaliation is taking action against a person as a result of their participation in any of the activities described in this policy and procedures including, but not limited to, making a report, filing a formal complaint, participating (or not participating) in an investigation, hearing, or appeals process. Retaliation is prohibited at Jefferson College, and is described more fully in Section IX.

## IV. PROHIBITED CONDUCT AND KEY PROVISIONS RELATED TO CONSENT

### Prohibited Conduct

Prohibited Conduct under this policy encompasses Sexual Harassment as defined below. These acts can occur between individuals who are known to one another, or have an intimate or sexual relationship, or may involve individuals who are not known to one another. These acts can be committed by person(s) of any sex, gender, or other identity, and it can occur between people of the same or different sex or gender identities.

Jefferson College prohibits the following types of conduct under this policy:

**1. Sexual Harassment:** Sexual Harassment is any conduct on the basis of sex that satisfies one or more of the following:

- a. An employee of the College conditioning the provision of an aid, benefit, or service of the College on an individual’s participation in unwelcome sexual conduct;
- b. Unwelcome conduct determined by a reasonable person to be so severe, pervasive, and objectively offensive that it effectively denies a person equal access to the school’s education program or activity; or
- c. **Sexual Assault, Dating Violence, Domestic Violence, or Stalking** as defined in the Clery Act amended by the Violence Against Women Act (VAWA).

**i. Sexual Assault:** Sexual Assault is any sexual act directed against another person, without the consent of the victim, including instances where the victim is incapable of giving consent. Sexual Assault includes, but is not limited to, the following acts when they occur without consent of the victim:

- Any penetration, however slight, of the genitals or anus of one person with the genitals of another person,
- Any act involving the genitals of one person and the hand, mouth, tongue, or anus of another person,
- Any sexual act involving penetration, however slight, of the genitals or anus of one person by a finger, instrument, or object,
- Touching of another person’s genitals or breasts under or over the clothing,
- Touching of one person with the genitals of another person under or over the clothing.

Sexual assault is also an offense that meets the definition of fondling, incest, or statutory rape as used in the FBI’s Uniform Crime Reporting system.

1. **Fondling:** The touching of the private body parts of another person for the purpose of sexual gratification, without the consent of the victim, including instances where the victim is incapable of giving consent because of their age or because of their temporary or permanent mental incapacity.
2. **Incest:** Sexual intercourse between persons who are related to each other within the degrees wherein marriage is prohibited by law.
3. **Statutory Rape:** Sexual intercourse with a person who is under the statutory age of consent.

**ii. Dating Violence:** Violence committed by a person who is or has been in a social relationship of a romantic or intimate nature with the victim (Complainant). The existence of such a relationship shall be based on consideration of the following factors that include the length of the relationship, the type of relationship, and the frequency of interaction between the persons involved in the relationship. Dating Violence includes, but is not limited to, sexual or physical abuse or the threat of such abuse. Dating Violence does not include acts covered under the definition of Domestic Violence.

**iii. Domestic Violence:** A felony or misdemeanor crime of violence committed by a current or former spouse or intimate partner of the victim (Complainant); by a person with whom the victim shares a child in common; by a person who is cohabitating with, or has cohabitated with, the victim as a spouse or intimate partner; by a person similarly situated to a spouse of the victim under the domestic or family violence laws of the jurisdiction in which the crime of violence occurred; or by any other person against an adult or youth victim who is protected from that person's acts under the domestic or family violence laws of the jurisdiction in which the crime of violence occurred.

**iv. Stalking:** Engaging in a course of conduct directed at a specific person that would cause a reasonable person to fear for their safety or the safety of others or suffer substantial emotional distress. Course of conduct means two or more acts, including, but not limited to, acts in which the stalker directly, indirectly, or through third parties, by any action, method, device, or means, follows, monitors, observes, surveils, threatens, or communicates to or about, a person, or interferes with a person's property. Substantial emotional distress means significant mental suffering or anguish that may, but does not necessarily require medical or other professional treatment or counseling. Reasonable person means a reasonable person under similar circumstances and with similar identities to the victim.

The State of Missouri's Revised Statutes provide information on state laws pertaining to the offenses listed in the above section. More information on the State of Missouri Statutes as it pertains to sexual offenses (including sexual assault, rape, and statutory rape) can be found in RSMo 566. More information on the State of Missouri Statutes as it pertains to Incest can be found in RSMo 568; information on Domestic Violence can be found in RSMo 565; and Stalking can be found in RSMo 565. All Revised Statutes for the State of Missouri can be accessed online at: [revisor.mo.gov/main/Home.aspx](http://revisor.mo.gov/main/Home.aspx).

### **Consent, Force, Coercion, and Incapacitation**

As noted in the above definitions of Prohibited Conduct, occurrences of Sexual Harassment involve acts that occur without consent. This section will further define and clarify consent, force, coercion, and incapacitation as it relates to Prohibited Conduct under this policy.

#### **Effective Consent**

Consent is an active, conscious, voluntary, and freely-given decision by each participant to engage in mutually agreed-upon sexual activity. Consent must exist from the start to the finish of each form of sexual contact. Consent consists of mutually understandable words and/or actions that indicate a willingness to engage freely in sexual activity. Consent can never be effectively gained by force, threats, coercion, or by taking advantage of the incapacitated state of another individual. A lack of physical resistance or a lack of verbal refusal does not indicate that the person is providing consent. Consent may not be assumed or inferred based upon silence, passivity, lack of resistance, or lack of active response.

Any party may withdraw their consent for the sexual activity at any time during the sexual activity. Withdrawal of consent may be demonstrated in a variety of ways through words or actions that indicate a desire to end the sexual activity. Once consent is withdrawn, sexual activity must cease immediately. Recognizing the dynamic nature of sexual activity, individuals choosing to engage in sexual activity must evaluate consent in an ongoing manner and communicate clearly throughout the states of sexual activity. Consent to one form of sexual contact does not constitute consent to all forms of sexual contact. Consent to sexual activity with one person does not constitute consent to activity with any other person. Each participant in a sexual encounter must consent to each form of sexual contact with each participant. Additionally, individuals with a previous or current intimate relationship to each other do not automatically give initial or continual consent to sexual activity. The mere fact that there has been prior intimacy or sexual activity does not, by itself, imply consent to future acts.

There are times when a person may give consent but the consent may not be considered effective. An individual who is under force, threat of force, coerced, or incapacitated is considered unable to provide effective consent. These situations are outlined in the next sections.

#### **Force and Coercion**

Force is the use or threat of physical violence, intimidation, or coercion in order to overcome another individual's freedom to choose whether or not to participate in sexual activity. For the use of force to be demonstrated, there is no requirement that an individual resist the sexual advance or request; however, resistance will be viewed as a clear demonstration of non-consent.

Coercion is the use of unreasonable pressure that compels another individual to initiate or continue sexual activity against their will. Coercion can include a range of behaviors, including physical/emotional force, intimidation, manipulation, implied threats, misuse of authority, or blackmail which places a person in fear of immediate harm or physical injury that causes them



to engage in undesired sexual activity. Continuing to pressure an individual who has made it clear that they do not want to engage in sexual activity or go beyond a certain point of sexual interaction may be considered coercive. When evaluating coercive behavior, factors such as the frequency, duration, location (in regard to potential isolation of the recipient of the unwanted sexual contact), and intensity of coercive behaviors will be considered.

### **Incapacitation**

Incapacitation is a state where an individual is unable to make an informed decision to engage in sexual activity because they lack conscious knowledge of the nature of the act (an ability to understand the who, what, when, where, why, or how of the sexual interaction). An individual who is incapacitated is unable to provide effective consent. An individual who knows or who should have reasonably known under the circumstances that the individual(s) they are attempting to or have engaged in sexual activity with violates this policy if the behavior falls within the elements found in the Prohibited Conduct section of this policy. Behavior that may occur outside of the elements of Prohibited Conduct may be addressed by other College policies and procedures.

Incapacitation is defined as the inability, temporarily or permanently, to give consent because the individual is mentally and/or physically unable to make informed, reasonable judgements. An individual is incapacitated, and therefore unable to provide effective consent, if they are asleep, unconscious, or otherwise unaware that sexual activity is occurring.

Incapacitation may result from the use of alcohol and/or drugs. Incapacitation is a state beyond drunkenness or intoxication. Consumption of alcohol or other drugs alone is insufficient to establish incapacitation. The impact of alcohol and drugs varies from person to person; however, warning signs that a person may be approaching incapacitation include slurred speech, vomiting, diminished coordination, erratic behavior, combativeness, loss of consciousness, or emotional volatility. Evaluating incapacitation requires an assessment of how the consumption of alcohol and/or drugs affects an individual's decision-making ability, awareness of consequences, ability to make informed judgments, and/or capacity to appreciate the nature of the act(s).

Evaluating incapacitation also requires an assessment of whether a person should have been aware of the other individual's (or individuals') incapacitation based on objectively and reasonable apparent indications of impairment when viewed from the perspective of a reasonable sober person. If there is any doubt as to the level or extent of the other individual's intoxication or impairment, the safest course of action is to forgo or cease any sexual contact or activity. Use of alcohol or drugs is never an excuse for a person to commit Sexual Harassment (inclusive of all forms of sexual assault, dating violence, domestic violence, and stalking under this policy) and does not diminish a person's responsibility to obtain informed, freely-given, and effective consent.

## **V. REPORTING PROHIBITED CONDUCT**

Jefferson College strongly encourages the prompt reporting of any incident of sexual or gender-based discrimination or harassment to the College. Because behavior that violates this policy may also be a violation of law, any individual who has been subjected to sexual assault or harassment is also encouraged to consider criminal or civil legal options. An individual may also file a complaint with the U.S. Department of Education's Office for Civil Rights, the Equal Employment Opportunity Commission, and/or the Missouri Human Rights Commission.

Upon receipt of information alleging a violation of this Policy, the Jefferson College Title IX Coordinator (or Deputy Title IX Coordinator) will respond promptly to the Complainant to present options for filing a formal complaint, to discuss the availability of and implementation of supportive measures designed to preserve educational and/or program access (including safety options and options for reporting to law enforcement), as well as to discuss the investigation and grievance process. The Title IX Coordinator will take the victim/Complainant's wishes into account when presenting information and evaluating whether or not to file a formal complaint against the responding party (Respondent).

Jefferson College is committed to providing an educational, working, and living environment free of any form of sex discrimination and harassment. The College is unable to take actions to address sex discrimination and harassment if the actions are not reported to the appropriate parties. Therefore, all employees of the College, unless specifically designated as a Confidential Reporting Source for Title IX, are required to report matters that fall under this Policy to the Title IX Coordinator or to a Deputy Title IX Coordinator.

Jefferson College's Confidential Reporting Source is any licensed mental health therapist contracted to provide counseling services for the student body. Additionally, although not confidential to the extent of a counselor, the Student Advocate is another resource a victim may speak to about what options and resources are available to them. The Student Advocate is exempt from reporting to the Title IX Coordinator; however, they may report non-identifying information to the Clery Officer

for crime statistic purposes. Both individuals are located on the second floor of the Student Center. Students can make an appointment with the licensed mental health therapist by calling (636) 481-3215 and with the victim advocate by calling (636) 481-3267. All other Jefferson College employees are instructed to report matters of sex or gender-based discrimination, harassment, and/or assault to the Title IX Coordinator as soon as they become aware of an incident.

Any person who is aware of or who has experienced any form of Sexual Harassment may make a report at any time, within or outside College business hours, to the Title IX Coordinator. Reports may be made by the person who experienced the unwanted contact but may be made by any person including third parties, students, staff, faculty, parents, or community members. These reports may be made in person, verbally, by phone, in writing through mail or electronic mail, through the College's Maxient reporting portal (found in MyJeffco or at [jeffco.edu/titleix](http://jeffco.edu/titleix)), or any other manner that delivers the information to the Title IX Coordinator at any time.

Jefferson College's Title IX Coordinator and Deputy Title IX Coordinators are listed below:

### **Title IX Coordinator**

Dr. Kimberly Harvey-Manus

Vice President of Student Services

Physical mailing address: 1000 Viking Drive, Student Center, Hillsboro, MO 63050

Office location: Student Center, 2nd floor, Room 205

Phone/Email: (636) 481-3200/[kh Harvey@jeffco.edu](mailto:kh Harvey@jeffco.edu)

### **Deputy Title IX Coordinators**

Tasha Welsh

Director of Human Resources

Office location: Administration Building, Room 133E

Phone/Email: (636) 481-3157/[twelsh@jeffco.edu](mailto:twelsh@jeffco.edu)

Kristine Bogue

Director of Student Compliance

Office location: Student Center, 2nd floor, Room 209

Phone/Email: (636) 481-3258/[kbogue1@jeffco.edu](mailto:kbogue1@jeffco.edu)

Dr. Michael Booker

Associate Dean, Humanities

Office location: Arts and Science I, Room 110

Phone/Email: (636) 481-3312/[mbooker@jeffco.edu](mailto:mbooker@jeffco.edu)

### **Privacy and Confidentiality in Reporting Prohibited Conduct**

Jefferson College will keep confidential the identity of any individual who has made a report or complaint of sex discrimination, including any individuals who have made a report or filed a formal complaint of Sexual Harassment, any Complainant, any individual who has been reported to be the perpetrator of sex discrimination, any Respondent, and any witness, except as may be permitted by:

- the FERPA (Family Educational Rights and Privacy Act) statute or FERPA regulations;
- requirements of law; or
- to carry out the purposes of the regulations of Title IX, including the investigation, hearing, or judicial proceeding arising as a result of allegations of sex discrimination or Sexual Harassment.
- In cases where a formal complaint has been filed, disclosures of identities are necessary in order to provide the proper notice as required under federal regulations. However, in all cases, the disclosure of personally identifiable information will be conducted with the utmost attention to the privacy of the individuals involved.

### **The Intersection of Title IX and The Clery Act**

In order to comply with the federal law known as the Clery Act, the College is required to collect and report specific statistical information related to incidents of sexual assault, domestic violence, dating violence, and stalking that take place on College owned or controlled properties or at College-sponsored programs or events. This information is provided to the College's Clery Compliance Coordinator for assessment for inclusion in daily crime statistics, timely warning reports, and for potential

inclusion in the College's Annual Safety and Security Report.

Jefferson College's Clery Compliance Coordinator is Officer Darrel Hulvey at the Campus Police Department. The information contained in Clery reports tracks the number of Clery-reportable offenses and does not include the names or identifying information about the person(s) involved in the report. The College may share non-identifying information about reports received in aggregate form.

- **Timely Warnings:** If a report of Sexual Harassment discloses a serious, immediate, or continuing threat to the Jefferson College community, the College may issue a campus-wide timely warning notification (which may be in the form of a text message, email message, or other electronic communication to the campus community members) to protect the health or safety of the community and to heighten safety awareness. The timely warning will not include any identifying information about the Complainant. The College reserves the right to send campus-wide notifications on a report of Sexual Harassment in compliance with timely warning regulations.

The Grievance Process at Jefferson College is conducted in compliance with the requirements of FERPA, Title IX, the Clery Act, the Violence Against Women Act, state law, federal law, and College policy. No information shall be released from these proceedings except as required or permitted by law and College policy.

### **Emergency Removals**

Where a report of Sexual Harassment (inclusive of sexual assault, domestic violence, dating violence, or stalking as defined in this policy) poses a substantial and immediate threat of harm to the physical health or safety of an individual or members of the College community, the College may place a student, employee, or student organization on an Emergency Removal. If an Emergency Removal is imposed, the individual(s) or organization may be denied access to any or all campus properties, campus facilities, and/or all other College activities or privileges for which the individual(s) or organization might otherwise be eligible. Where possible and academically feasible, the College will assist the Respondent in making alternative arrangements to continue and/or complete coursework. Specific guidelines for the restrictions will be communicated to the Respondent in writing when they are notified of the Emergency Removal. When an Emergency Removal is imposed, the College will make reasonable efforts to complete the investigation and full grievance process within an expedited time frame, barring any other circumstances that may lengthen any part of the grievance process.

The following steps will be taken with regard to Emergency Removals for Respondents under this Policy:

1. Prior to an Emergency Removal taking place, the College will undertake an individualized safety and risk analysis to determine whether or not there is an immediate threat to the physical health or safety of any student, employee, or other individual arising from the allegations of Sexual Harassment that justifies a removal.
2. The individualized safety and risk analysis may be performed by the Jefferson College Care Team, a licensed mental health counselor, or other third-party designated by the College with experience to conduct such assessments.
3. Should the Emergency Removal or Administrative Leave be implemented following an individualized safety and risk analysis, the Respondent(s) shall be provided with Notice of the Emergency Removal Order/Administrative Leave Order and an opportunity to challenge the decision following the removal.
4. The opportunity to present a challenge to the removal shall be completed as soon as possible in light of the circumstances.
5. For student Respondents, the challenge to an Emergency Leave Removal will be heard by the President or their designee.
6. For employee Respondents, the challenge to an Emergency Leave Removal will be heard by the Director of Human Resources, the Vice President of Instruction, or their designee.
7. The challenge or appeal of the Emergency Removal process shall be the same for students, staff, and faculty. A Respondent may respond to the Removal by presenting information, evidence, written information, and/or facts that support their challenge. The challenge will be heard face to face (meaning it may be done remotely provided the participants are able to see and/or hear each other in real time). The Respondent will have an opportunity to present their information and answer questions from the person who is hearing their challenge.
8. The person who is hearing the Respondent's challenge will then consider the information that has been provided to them in making their decision. The decision-maker has the discretion to speak to other parties who were involved in the Emergency Removal in making their decision. The decision-maker will provide a decision to the Respondent, in writing, as soon as possible within the existing circumstances. This decision is final.

## VI. SUPPORTIVE MEASURES

Supportive Measures are non-disciplinary, non-punitive measures put in place to assist any party impacted by Sexual Harassment in order to restore or preserve their equal access to their educational program, educational activity, or employment. Supportive measures are provided free of cost and may include such things as counseling services, safety escorts, reciprocal No Contact Orders, schedule changes, or living environment changes (where applicable). A full range of supportive measures and resources at the College and in the community are described within this Policy and procedures. Supportive measures can be used by any person involved in a report of Sexual Harassment regardless of whether or not a formal complaint is filed. Supportive Measures can remain in place regardless of the outcome of a Grievance Process and are available to students and employees throughout their time at the College. Students or employees who have questions about supportive measures that are available to them in the aftermath of sexual assault, domestic violence, dating violence, stalking, or any form of Sexual Harassment are strongly encouraged to contact the Title IX Coordinator to discuss their options.

### Jefferson College Supportive Measures

<b>COMTREA on campus mental health services for students:</b> Contact (636) 481-3215 to schedule an appointment and/or email <a href="mailto:counseling@jeffco.edu">counseling@jeffco.edu</a> .
<b>On-Campus Advocate:</b> Contact (636) 481-3267 to schedule an appointment and/or email <a href="mailto:alowery3@jeffco.edu">alowery3@jeffco.edu</a> .
<b>Central Methodist University Clinical Counseling Services for students (virtual appointments):</b> Email <a href="mailto:cccjeffco@centralmethodist.edu">cccjeffco@centralmethodist.edu</a> to schedule an appointment.
<b>Personal Assistance Services for full-time employees:</b> <a href="http://www.jeffco.edu/employee-resources/pas-employee-assistance-program">www.jeffco.edu/employee-resources/pas-employee-assistance-program</a> .
<b>Jefferson College Police Department:</b> Safety escorts may be provided as well as support for overall safety concerns. Contact (636) 481-3500 or 911 in an emergency.
<b>Academic Success Center:</b> Located on the first floor of the Technology Center on the Hillsboro campus, staff in the ASC can assist students with tutoring, test preparation, and writing skills. ASC also has resources at the Arnold/Imperial locations, and via online services.
<b>Financial Aid:</b> Located on the first floor of the Student Center, staff in Financial Aid can assist a student with questions or concerns related to their financial aid package.
<b>Disability Support Services:</b> Located on the first floor of the Technology Center, staff in DSS can assist students who may wish to learn more about disability accommodations on campus.
<b>Residential Life accommodations (when applicable):</b> This may include a room or apartment change, space permitting.
<b>Reciprocal No Contact Orders:</b> Either party may request a No Contact Order at any point in the process or in the absence of a formal complaint. No Contact Orders are reciprocal, non-punitive administrative orders from the school designed to preserve all parties' access to educational and employment opportunities.
<b>Change of Class Schedule or other academic arrangements:</b> Either party may request or be assigned a class schedule change as available. Other academic accommodations may be implemented in conjunction with the Title IX Coordinator and Instructional staff/faculty.
<b>Change of Working environment:</b> In conjunction with Human Resources and the Title IX Coordinator, employees (including student workers) may receive supportive measures within the working environment in order to maximize safety and minimize disruption.
<b>Supportive Measures</b> on campus can be implemented in conjunction with or in the absence of a formal complaint, and are available to any impacted party, including Complainants, Respondents, Witnesses, or other third-parties. For more information on support at Jefferson College, please visit: <a href="http://www.jeffco.edu/vikings-care">www.jeffco.edu/vikings-care</a> or <a href="http://www.jeffco.edu/titleix">www.jeffco.edu/titleix</a> .



**Community Resources – the Title IX Coordinator may refer a person to any of these community resources in order to provide additional support as needed.**

<p><b>Behavioral Health Response Hotline:</b> BHR provides confidential telephone counseling to people in mental health crises as well as mobile outreach services, community referral services, and critical incident stress management (CISM). BHR’s crisis hotline and mobile outreach services are provided free of charge to the public by paid professional staff who have master’s degrees in their respective behavioral science disciplines. (800) 811-4760 <a href="http://bhrstl.org/">bhrstl.org/</a></p>
<p><b>The Trevor Project:</b> National organization providing crisis intervention, resources, and suicide prevention services to LGBTQ young people ages 13-24. (866) 488-7386 (24/7) <a href="http://www.thetrevorproject.org">www.thetrevorproject.org</a></p>
<p><b>Trans Lifeline Hotline:</b> (877) 565-8860 A grassroots hotline and microgrants non-profit organization offering direct emotional and financial support to trans people in crisis - for the trans community, by the trans community.</p>
<p><b>Domestic Violence Shelter and support in Jefferson County:</b> A Safe Place, COMTREA (636) 232-2301, <a href="http://www.comtrea.org/services/community-services/domestic-violence">www.comtrea.org/services/community-services/domestic-violence</a></p>
<p><b>Sexual Assault and Interpersonal Violence Supportive Services:</b> Safe Connections Hotline at (314) 531-2003, <a href="http://safeconnections.org/">safeconnections.org/</a></p>
<p><b>Child Abuse Hotline online reporting</b> and other resource options for victims and families related to child abuse: <a href="http://dss.mo.gov/cd/keeping-kids-safe/can.htm">dss.mo.gov/cd/keeping-kids-safe/can.htm</a></p>
<p><b>Jefferson County Health Department</b> at (636) 797-3737, <a href="http://www.jeffcohealth.org/">www.jeffcohealth.org/</a></p>
<p><b>To obtain a forensic sexual assault examination</b> (often referred to as a “rape kit”) go to the Emergency Room of local hospitals such as Mercy South, Mercy Jefferson, Missouri Baptist, BJC, or Saint Louis University Hospital.</p>
<p><b>Legal Services of Eastern Missouri:</b> LSEM provides high-quality civil legal assistance for low-income people. Legal services are most frequently provided in areas relating to domestic violence and other family law issues, children, education, health, housing and homelessness, public benefits, elder law, immigration, and consumer matters. 4232 Forest Park Avenue St. Louis, MO 63108; (314) 534-4200 or (800) 444-0514.</p>
<p><b>Obtaining Orders of Protection in Jefferson County:</b> Any victim of stalking or an adult abused by a present or former spouse, adult family or household member, or adult who is or has been in a continuing social, romantic, or intimate relationship, or a person with whom the victim has a child may file for an ex parte order of protection. No filing fee, court costs, or bond is required to file, nor do you need a lawyer to file. The petition must be filed in the county where the petitioner resides, where the alleged abuse occurred, or where the Respondent may be served. Jefferson County Courthouse, 300 Main Street Hillsboro, MO 63050; (636) 797-5443.</p>
<p><b>Jefferson County Sheriff’s Office:</b> The sheriff’s department will apprehend criminals and investigate crimes in Jefferson County. The sheriff’s department has also designated a victim services coordinator who can be reached at (636) 797-5017 or <a href="mailto:pshort@jeffcomo.org">pshort@jeffcomo.org</a>. The Sheriff’s office is located at 400 1st Street, Hillsboro, MO 63050. (636) 797-5000.</p>
<p><b>For questions or concerns related to Immigration:</b> United States Citizenship and Immigration Services department offers assistance for those seeking citizenship, green cards, and working in the United States. <a href="http://www.uscis.gov">www.uscis.gov</a></p>
<p>Any person desiring more information on College or Community Resources in the aftermath of any form of sexual assault or sexual harassment is strongly encouraged to contact the Title IX Coordinator at (636) 481-3200 and/or make a report to local law enforcement.</p>

## VII. FILING A FORMAL COMPLAINT AND INITIATING THE GRIEVANCE PROCESS

### a. Filing a Formal Complaint

Any person may make a report of behavior that they believe to fall under this Policy and Procedures. This includes any student, faculty member, staff member, parents or legal guardians of a student, or a third-party not directly affiliated with the College. Upon receiving a report, the Title IX Coordinator will communicate with the Complainant to discuss all options, resources, and supportive measures available to them (supportive measures are available regardless of whether or not a formal complaint is filed) as the person who is reported to have experienced the Sexual Harassment. The Complainant’s wishes with regard to filing a formal complaint will be taken into account, and the Title IX Coordinator will work with College resources to implement supportive measures as requested or needed.

In cases where the identity of the Complainant is either not known or has not been disclosed, the Title IX Coordinator or their designee will make reasonable efforts to ascertain the identity of the Complainant. The College is unable to act on a formal complaint for anonymous parties or in the absence of the knowledge of the identity of the Complainant. A formal complaint may be filed in one of two ways:

1. The Complainant can choose to initiate the formal complaint and grievance process by, in writing or via electronic message, indicating to the Title IX Coordinator their desire to have the College investigate their report. The complaint must be signed (either physically or digitally, or in some other way that makes it clear that the Complainant is the person filing the complaint) and sent to the Title IX Coordinator. The Complainant must be the person who experienced the Sexual Harassment and who is participating in or attempting to participate in the College's education activity or programs. A person who is not affiliated with the College is unable to initiate a formal complaint under these procedures.
2. Where a Complainant may decline to file a formal complaint, the Title IX Coordinator will assess the known circumstances of the situation and determine whether or not a formal complaint will be filed by the Title IX Coordinator themselves. In this situation, the Title IX Coordinator will contact the Complainant to discuss supportive measures, the filing of a formal complaint, and the grievance process. The Title IX Coordinator will take the Complainant's wishes into account as well as the need for campus safety when evaluating whether or not to file a complaint. In the event that the Title IX Coordinator initiates the formal complaint and grievance process, the Title IX Coordinator does not become the Complainant but is still responsible for the coordination of an equitable and thorough grievance process.

Jefferson College seeks to remove barriers to individuals reporting Sexual Harassment. An individual who reports or who is involved in a report of Sexual Harassment will not be subject to disciplinary action for their own personal consumption of alcohol or drugs at or near the time of the incident, provided that such violations did not and do not place the physical health or safety of another person at risk. Jefferson College may initiate an educational discussion or pursue other educational or therapeutic methods regarding alcohol or other drugs for those individuals.

Except in the cases outlined in the next two subsections, if a formal complaint is filed, the College will investigate and resolve the allegations of Sexual Harassment through the grievance process described within this policy and procedures.

Jefferson College reserves the right to consolidate formal complaints of allegations of Sexual Harassment against more than one Respondent, or by more than one Complainant against one or more Respondents, or by one party against the other party, where the allegations of Sexual Harassment arise out of the same facts or circumstances.

#### **b. Mandatory Dismissal of Formal Complaints**

Jefferson College will investigate allegations in a formal complaint, unless the College is prohibited from doing so by Title IX regulations or other laws. The school is obligated to dismiss a formal complaint (in part or in whole) in these circumstances:

1. If the reported conduct in a formal complaint would not constitute Sexual Harassment as defined in this policy and procedures even if proved.
2. The formal complaint is signed by someone who does not meet the definition of a Complainant or who is not the Title IX Coordinator in cases where the Title IX Coordinator initiates the formal complaint.
3. The formal complaint is filed against someone who is not a part of Jefferson College's education program or activity (i.e. the Respondent was not affiliated with the College).
4. If the reported conduct in a formal complaint did not occur within Jefferson College's education program or activity, or did not occur against a person in the United States, then the school must dismiss the formal complaint with regard to that conduct for the purposes of this policy.
5. In cases of mandatory or discretionary dismissals of formal complaints (whether in whole or part), Jefferson College reserves the right to address the conduct under other applicable policies and procedures, including but not limited to, Board of Trustee Policies and Procedures, Human Resources procedures, and Student Conduct procedures.
6. Upon receipt of a formal complaint, the Title IX Coordinator will review the allegations set forth and determine whether the complaint may proceed. After an initial review of the formal complaint, the Title IX Coordinator will continue to monitor the investigation and evaluate the formal complaint to determine if the above criteria for dismissal apply.

#### **c. Discretionary Dismissal of Formal Complaints**

Jefferson College may dismiss a formal complaint, or the allegations contained within a formal complaint under these three circumstances:

1. A formal complaint may be dismissed if, at any time during the investigation or hearing, a Complainant notifies the Title IX Coordinator in writing that they would like to withdraw the formal complaint or any allegations within the complaint.
2. A formal complaint may be dismissed if the Respondent (student or employee) is no longer enrolled or employed by the school.
3. A formal complaint may be dismissed if specific circumstances prevent the school from gathering information sufficient to reach a determination as to the formal complaint or the allegations contained within the formal complaint.

#### **d. Notification of Complaint Dismissal**

In any case where a formal complaint is dismissed, whether it be due to mandatory or discretionary reasons, the Title IX Coordinator will notify the party (or parties) in writing (via electronic communication) as to the dismissal and the reason(s)/rationale for the dismissal. In cases of mandatory or discretionary dismissal, both parties will have an equal opportunity to submit an appeal of that decision (whole or in part). The next section provides information on the process for appealing the decision to dismiss all or part of a formal complaint.

#### **e. Appealing the Decision to Dismiss all or part of Formal Complaint**

Either party may submit an appeal of the decision to dismiss all or part of a formal complaint, in writing, on any of the following bases, within five (5) College business days of the issuance of the Notification of Formal Complaint Dismissal:

1. Procedural Irregularity: There was a procedural irregularity that affected the decision to dismiss the formal complaint.
2. New Information/Evidence: There is new information that was not reasonably available at the time the determination regarding dismissal was made, and the information is such that it could affect the outcome of the matter.
3. Conflict of Interest or Bias on the part of persons involved in the process: The Title IX Coordinator, Investigator(s), and/or other Decision-Maker(s) had a conflict of interest or bias for or against Complainants or Respondents generally or the individual Complainant or Respondent and it affected the outcome of the matter.

Once an appeal is filed by either party, the Title IX Coordinator will notify the other party in writing that an appeal has been filed and implement appeal procedures equally for both parties. Appeal procedures are as follows:

1. Appeals are to be submitted in writing to the Title IX Coordinator by the deadline specified in Notification of a Dismissal of Formal Complaint, which will be set at five (5) College business days from the date of issuance of the notification.
2. Either party may submit an appeal on the bases listed above. More than one appeal base may be used in an appeal.
3. The Title IX Coordinator will notify the other party of the presence of an appeal, if applicable.
4. The party or parties will have an equal opportunity to submit, in writing, a statement of support of the outcome or a challenge of the decision.
5. The Title IX Coordinator will ensure that the person(s) hearing the appeal were not involved in the Complaint Dismissal decision. Persons who hear an appeal under this policy may be persons within the College community or third parties external to the College community, selected by the Title IX Coordinator or their designee. In all cases, person(s) hearing an appeal will have the required training to implement fair and effective appeal processes.
6. The person(s) assigned to hear the appeal (the “appeal body”) may review the information and statements submitted by the parties, as well as be provided access to discuss the information with the parties at their discretion.
7. The appeal body will issue a written decision describing the result of the appeal and the rationale for the result of the appeal generally within ten (10) College business days of the receipt of the appeal(s). If the appeal process requires additional time to render a written result and rationale, the Title IX Coordinator will notify both parties of any delay or extension of time within this process.
8. The appeal body’s written outcome letter will be delivered to both parties via electronic message simultaneously.
9. The decision of the appeal body is final.

### **VIII. GRIEVANCE PROCESS**

Once the procedures outlined in Section VII have been implemented in order to file a formal complaint, the Grievance Process has been initiated and the following actions will take place.

#### **a. Notification of Formal Complaint and Investigation**

The Title IX Coordinator or their designee will select a trained Investigator (or Investigators) from within or external to the Jefferson College community. The Title IX Coordinator or designee will assess any Investigator(s) chosen to make sure that they are free of bias or conflict of interest.

The Investigator will review the formal complaint and provide a Notice of Formal Complaint and Investigation to both the Complainant and Respondent. This Notice will contain, but is not limited to, the following elements:

1. Information about the grievance process;
2. Notice of the allegations of Sexual Harassment that potentially align with the definition(s) found in this Policy and Procedures;
3. Sufficient details, including the identities of the parties involved in the incident (if known), the conduct reportedly constituting Sexual Harassment, and the date and location of the reported incident (if known);
4. A statement that the Respondent is presumed not responsible for the reported conduct and that a determination

- regarding responsibility is made at the conclusion of the grievance process;
5. Information regarding the rights of both parties to have any one (1) Advisor of their choosing, who may be but is not required to be an attorney (at their own expense), present with them at any meeting, hearing, or other proceeding under this Policy and Procedures;
  6. Information regarding both parties' (and their Advisor's) rights to review and inspect information gathered during the investigation as well as prior to any hearing; and
  7. Notice that if, during the course of the investigation, the Investigator(s) choose to investigate allegations about the Complainant or the Respondent that were not included in the initial Notice, that they will provide notice of the additional allegations to the parties whose identities are known.

### **b. Investigation Procedures**

The investigation is designed to provide a fair, thorough, and impartial gathering of facts. All individuals participating in an investigation will be treated with respect. The College will seek to complete an investigation within sixty (60) College business days of providing Notice of the Investigation, but this time frame may be extended depending on the individual circumstances of each report.

At the request of local law enforcement, the College may agree to defer for a short time its fact gathering until after the initial stages of a criminal investigation. The College will promptly resume its fact gathering as soon as it is informed that local law enforcement has completed its initial investigation.

At all times the burden of proof and gathering evidence or information sufficient to reach a determination of responsibility (based on the preponderance of the evidence standard) is upon the College and not on the parties themselves. However, parties shall have equal opportunity to provide information in the form of participating in investigative interviews and meetings, providing written or electronic statements, and providing other evidence and documents such as texts, videos, social media postings, or other materials. Both parties will be given opportunity to recommend witnesses, including expert witnesses (services provided by expert witnesses requested by the parties shall be paid for by the parties themselves), to the Investigator(s).

The College will not, in gathering facts during an investigation, seek to access or disclose any party's records that are made or maintained by a physician, psychiatrist, psychologist, or other recognized professional or paraprofessional acting in their professional or paraprofessional capacity to provide treatment or legally privileged counsel to that party. A participant who wishes to have their own records provided for the purposes of an investigation may choose to do so at their own discretion and by providing a voluntary, written consent to do so. Parties who choose to waive any privilege of confidentiality afforded to them do so with the knowledge that the other party (or parties) involved in the grievance process will be provided with access to inspect, review, and respond to that information during the course of the grievance process.

Neither the Complainant nor the Respondent shall be placed under any restriction that prohibits their ability to discuss the allegations under investigation or to gather and present relevant information or evidence to the Investigator. All parties involved in any part of the grievance process are expected to provide truthful information. Any person found to have provided knowingly false information in bad faith may be subject to disciplinary processes under student or employee procedures at the College.

During the Investigation, the Investigator will seek to complete meetings, interviews, or other methods of communication with the Complainant, the Respondent, witnesses provided by either the Complainant/Respondent, as well as any witnesses that the Investigator identifies. Witnesses must be persons who may have observed the acts in question, may have relevant information to share, or who offer information related to a party's individual character. The Investigator will gather all information, including supplemental information, which may take the form of electronic communication records, text messages, written statements, photographs, videos, social media postings, or other information pertaining to the allegations. All participants that the Investigator seeks to gather information from will be notified of any investigative meetings or interviews in writing with the proposed date, time, location, participants, and purpose of the meeting identified. Every participant shall be given sufficient time to prepare for any investigative meeting or interview.

The Complainant and Respondent shall have equal rights to have any one (1) Advisor of their choosing present with them at any meeting for the investigation or hearing. An Advisor may be, but is not required to be, an attorney. Any attorney hired by a party to serve as their Advisor shall be done so at the individual party's expense. A Complainant or Respondent who does not have an Advisor may request that the Title IX Coordinator assign an Advisor to them. The Advisor may be a trained employee of Jefferson College or a third-party that the Title IX Coordinator designates. During an investigative meeting or interview, the party may consult with their Advisor as needed; however, the Advisor is not permitted to speak



on behalf of the party. Information provided during investigations shall be provided by the Complainant or Respondent themselves and will apply equally to both parties.

The Investigator (or Title IX Coordinator, as applicable) will provide regular updates to both the Complainant and Respondent on the status of the investigation throughout all stages of the investigation and notify each party as to any delays or issues that may lengthen the investigation timeline.

#### **c. Investigation Procedures Continued: Right to Review and Respond to the Investigative Report**

Prior to the finalization of the investigative report, the Investigator will compile all information that has been gathered and is directly related to the allegations. The Investigator will compile this information into a written report format, including any supplemental information, and notify both parties and their respective advisor simultaneously through electronic communication (through the use of the Jefferson College email system) of the availability of this information for their review and response.

The Investigator will provide the parties with an electronic copy of the report and associated materials accessible through the Jefferson College Google Drive system. Each party's Advisor will also receive the materials through the Google Drive system. These materials will be available to the parties and each party's advisor for their review and response within ten (10) College business days. During or by the conclusion of the initial review period, either party may submit written responses to any of the information contained in the report materials. Parties may also submit additional information they wish to have included at this stage.

#### **d. Conclusion of Investigative Process**

At the conclusion of the review period, the Investigator will compile, add, and review information submitted by the parties. Should the Investigator identify additional interviews or information gathering that may need to take place, they have the discretion to do so at this stage. This may extend the approximate investigation timeline. The Investigator will provide written updates to the parties informing them of any reasons that the investigation timeline will be lengthened.

Upon the conclusion of the initial review and response by the parties as well as any additional information gathering determined by the Investigator, the Investigator will finalize the report and prepare the report materials to be sent to the Hearing Officer(s) in preparation for a live hearing. Both the Complainant and the Respondent (and their Advisors) will be notified when the report materials have been finalized and be provided with a minimum of ten (10) College business days prior to any hearing where they are given an electronic copy viewable through the Google Drive system in order to review and respond to (written response) any report materials in preparation for the hearing.

#### **e. Hearing Process Overview**

Upon the conclusion of an investigation, the Investigator(s) will ensure all report materials are available for the Title IX Coordinator and any individual(s) designated to render a determination of responsibility in order to facilitate the scheduling of a hearing. Both the Complainant and Respondent shall have a minimum of ten (10) College business days prior to any hearing where they will have electronic access to view all report materials in order to prepare for the hearing. Both the Complainant and Respondent have the opportunity to submit a written response to any of the finalized report materials in advance of a hearing. The Investigator will receive any additional written responses and ensure that they are provided to the Title IX Coordinator and any individual(s) designated as a Hearing Officer prior to the hearing.

The Title IX Coordinator, in conjunction with other partners at the College such as Deputy Title IX Coordinators or other College leadership, will assist in the scheduling, coordination, and implementation of a live hearing, as set forth below and in subsequent sections:

1. Hearings shall be conducted live. A hearing may be conducted with parties in remote locations or virtually, provided that the parties are able to see and hear each other simultaneously. The Complainant and Respondent are not required to be in the same room during a hearing provided the conditions for viewing and hearing simultaneously are met as stated above.
2. The College will provide an individual (or individuals, at their discretion) to serve as a Hearing Officer, who will make the determination as to whether this policy was violated. The Hearing Officer will have the appropriate training and experience to serve in this role and may be someone who works at the College or who is hired/contracted externally by the College to fulfill this role. The parties and their Advisors will receive a notification advising them of the date, time, location, Hearing Officer(s) identity, and listing of other requested participants no less than ten (10) College business days in advance of the hearing. A hearing may be delayed or rescheduled at a party's request

provided the party submits information showing good cause for the delay to the Title IX Coordinator within three (3) College business days of the hearing. The Title IX Coordinator will notify each party of any delays or rescheduled hearings. Both the Complainant and Respondent (along with their Advisors) may meet with or speak to the Title IX Coordinator to ask questions about the hearing process prior to the hearing.

3. Any witness whose presence is requested at a hearing shall receive a written notification advising them of the date, time, purpose, and location of the hearing. Any party (including witnesses) that wishes to ask questions about the hearing process may meet with or speak to the Title IX Coordinator prior to the hearing.
4. The Title IX Coordinator or their designee will assist in providing technical and logistical support for the hearing, including the scheduling, preparation, and notifications of parties to be present at a hearing. Person(s) involved in making a decision at the hearing will also have received training or information prior to the hearing regarding the type of technology that will be used.

#### **f. Hearing Process Continued – Questioning and Cross-Examination Procedures**

During the live hearing, the Hearing Officer(s) as well as each party's Advisors will be provided with an opportunity to ask the parties as well as witnesses relevant questions and follow up questions, including questions that challenge credibility. The Hearing Officer(s) will ask their questions and follow up questions first, followed by each party's Advisor. Federal regulations stipulate that each party's Advisor be provided with the opportunity to "cross examine" the other party as well as witnesses during the hearing.

Questioning and cross-examination of the parties and witnesses must be conducted directly, orally, and in real time by the party's Advisor. At no time are the parties themselves permitted to engage in the questioning and cross-examination process. If a party does not have an Advisor of their choice present at the hearing, the Advisor does not agree to adhere to the standards of conduct for participants in a live hearing, or the Advisor refuses to engage in asking questions or conducting cross-examination, the College will provide to the party an Advisor of the College's choice, at no cost to any party, in order to perform questioning and cross-examination during the hearing proceedings. In some circumstances, this may mean the live hearing is delayed or rescheduled.

#### **g. Standards of Conduct during a Hearing and Prohibited Questions or Topics**

All participants in a live hearing are expected to conduct themselves in accordance with the "Rules of Decorum and Order for Hearings" which will be provided to participants prior to the hearing. These rules are put in place to maintain order within the hearing and to ensure that all participants are treated with respect and dignity. Accordingly, it is up to the Hearing Officer(s) discretion to address violations of the orders of decorum during the hearing. An individual who repeatedly refuses to adhere to the rules governing conduct during a hearing may be subject to ejection from the hearing or additional actions under other College policies.

Cross-examination questions or other questions that may be asked of a party or witness must be relevant to the incident(s). Questions, evidence, or other information about the Complainant's sexual predisposition are not permitted. Questions, evidence, or other information about prior sexual behavior are not permitted, unless such questions or information are offered to prove that someone other than the Respondent committed the conduct alleged by the Complainant, or if the questions and evidence concern specific incidents of the Complainant's prior sexual behavior with respect to the Respondent and are offered to prove consent. Before a Complainant, Respondent, or witness answers a question or cross-examination question, the Hearing Officer(s) must determine whether the question is relevant. If the Hearing Officer(s) determines that the question is not relevant and therefore is to be excluded, they must provide an explanation as to why the question will be excluded. The Hearing Officer will provide that explanation during the hearing, and may, at their discretion choose to provide additional information during the hearing or after the hearing.

The Hearing Officer(s) may evaluate and consider all relevant evidence, including but not limited to, statements by parties or witnesses during the investigation, information presented by parties or witnesses at the hearing, information contained in the investigation report, and information gathered during the investigation. This could also include police reports, Sexual Assault Nurse Examiner documents, medical reports, text messages, social media posts or messages, or other documents. When making the determination on responsibility, the Hearing Officer(s) may determine the weight to give statements and evidence based on the reliability and/or credibility of the statements and evidence.

The Hearing Officer, when formulating their determination regarding responsibility, is not permitted to make a finding or draw an inference regarding responsibility based solely on a party or witness's absence from the live hearing or refusal to answer cross-examination or other questions.

#### **h. Record of Hearing**

Jefferson College will create an audio recording of a live hearing and may choose to additionally create a transcript of a live hearing. In either case, the audio recording and/or transcript of a live hearing will be available to either party for inspection or review following the conclusion of a hearing as well as during any appeal process. This record will be kept for a period of seven years in accordance with the record-keeping procedures found in Section X of this policy and procedures.

#### **i. Determination of Responsibility and Standard of Evidence/Information**

The Hearing Officer will issue a written determination regarding responsibility generally within fifteen (15) College business days after the conclusion of the hearing. There may be circumstances where additional time to reach and communicate a determination of responsibility, and in that event the Hearing Officer or Title IX Coordinator will notify both parties of any delays.

The Hearing Officer will apply the preponderance of the evidence standard (i.e. “is it more likely than not”) to determine if it is more likely than not that the Respondent is or is not responsible for a violation (or violations) of this Policy.

The Hearing Officer will not make a decision solely based on the party’s role in the process, meaning that no individual will be found responsible solely because they are accused of misconduct. A Hearing Officer, once they have reached their decision, will communicate their written determination to the parties simultaneously via electronic communication.

The Notification of Determination Regarding Responsibility from the Hearing Officer will include the following elements:

1. Identification of the allegations potentially constituting Sexual Harassment under this Policy and Procedures.
2. Description of the procedural steps taken from the receipt of the formal complaint through the determination. This description will also include information about the notifications that were sent to the parties, interviews and meetings that took place with the parties and witnesses, site visits, other methods that may have been used to gather information or evidence, and hearings held.
3. Findings of fact supporting the determination.
4. Conclusions regarding the application of Jefferson College’s policies to the facts.
5. Statement of and rationale for the result as to each allegation, including a determination of responsibility, any disciplinary sanctions to be imposed on a Respondent, and whether remedies designed to restore or preserve equal access to the school’s education program or activity will be provided to the Complainant. The Title IX Coordinator is the staff member responsible for implementing any remedies that are put in place as the result of a concluded grievance process.
6. Description of the procedures and bases for an appeal that are available to both the Complainant and Respondent.

The determination regarding responsibility becomes final either on the date that the parties are provided with the written determination on the result of an appeal, if an appeal is filed, or if an appeal is not filed the determination becomes final on the date on which an appeal would no longer be considered timely. Deadlines for appeal submissions follow the procedures found in section VIII, subsection “K” below.

#### **j. Sanctions, Remedies, and Continuations of Supportive Measures following a Determination of Responsibility**

##### **Sanctions**

A Hearing Officer has the discretion to assign sanctions and remedies following a determination of responsibility where the Respondent has been found to be in violation of this policy. Sanctions are disciplinary actions consisting of one or more of the following: formal/final/written warnings, disciplinary probation, employment probation, loss of privileges, loss of access to all or parts of campus, restitution/community service, educational sanctions, counseling, mandated counseling or assessments, classes, fines, suspension, expulsion, temporary or permanent removal from employment, or other disciplinary actions or sanctions either found in College publications or assigned at the discretion of the Hearing Officer(s).

##### **Remedies**

Remedies are measures designed to restore or preserve a Complainant’s equal access to Jefferson College’s education program or activity following the conclusion of a grievance process where the Respondent has been found responsible for a violation (or violations) of this policy. Remedies may include a continuation of supportive measures for a Complainant that were put in place prior to or during the grievance process.

Remedies may also be disciplinary actions or sanctions that are punitive in nature, and differ from Supportive Measures. Please refer to Section VI for a description of Supportive Measures.

### **k. Appealing the Determination of Responsibility from a Hearing**

Following the issuance of a Hearing Outcome Letter (Determination of Responsibility and/or Non-Responsibility for violation(s) of this Policy), both the Complainant and the Respondent shall have equal rights to appeal the outcome. The Hearing Outcome Letter that is issued to both parties will outline the appeal process, bases for appeal, and appeal deadlines. The Title IX Coordinator will contact both parties to discuss the appeal process and answer questions about the appeal process that either party may have.

Either (or both) parties may submit an appeal of the determination, in writing, on any of the following bases, within ten (10) College business days of the issuance of the Hearing Outcome letter:

1. Procedural Irregularity: There was a procedural irregularity that affected the outcome of the matter.
2. New Information/Evidence: There is new information that was not reasonably available at the time the determination regarding responsibility was made, and the information is such that it could affect the outcome of the matter.
3. Conflict of Interest or Bias on the part of persons involved in the process: The Title IX Coordinator, Investigator(s), and/or Decision-Maker(s) had a conflict of interest or bias for or against Complainants or Respondents generally or the individual Complainant or Respondent and it affected the outcome of the matter.

Once an appeal is filed by either party, the Title IX Coordinator will notify the other party in writing that an appeal has been filed and implement appeal procedures equally for both parties. Appeal procedures are as follows:

1. Appeals are to be submitted in writing to the Title IX Coordinator by the deadline specified in the Hearing Outcome Letter, which will be set at ten (10) College business days from the date of issuance of the Hearing Outcome Letter.
2. Either party may submit an appeal on the bases listed above. More than one appeal base may be used in an appeal.
3. The Title IX Coordinator will notify the other party of the presence of an appeal.
4. Both parties will have an equal opportunity to submit, in writing, a statement of support of the outcome or a challenge of the outcome.
5. The Title IX Coordinator will ensure that the person(s) hearing the appeal were not involved in the investigation, hearing, or determination of responsibility process. Persons who hear an appeal under this policy may be persons within the College community or third parties external to the College community, selected by the Title IX Coordinator or their designee. In all cases, person(s) hearing an appeal will have the required training to implement fair and effective appeal processes.
6. The person(s) assigned to hear the appeal will review the information and statements submitted by the parties, as well as be provided access to review the investigative report and record of the hearing.
7. The appeal body will issue a written decision describing the result of the appeal and the rationale for the result of the appeal generally within fifteen (15) College business days of the receipt of the appeal(s). The appeal body may alter the hearing decision with regard to responsibility, and/or assign/modify remedies and/or sanctions. If the appeal process requires additional time to render a written result and rationale, the Title IX Coordinator will notify both parties of any delay or extension of time within this process.
8. The appeal body's written outcome letter will be delivered to both parties via electronic message simultaneously.
9. The decision of the appeal body is final and concludes the grievance process. Once the grievance process is concluded, any sanctions or remedies will be considered final and implemented by the Title IX Coordinator or designee(s).

### **l. Grievance Process Timeframes**

The entire grievance process may take approximately 120 College business days to complete. This timeframe includes the following approximations for each part of the process. This timeframe may be shorter or longer, depending on the factors and circumstances of each individual situation. Any delays for any part of the processes listed below will be communicated to both parties, in writing, and delivered simultaneously through electronic message.

1. Investigation Process: 60 College business days
2. First required review and response period following investigation: 10 College business days. The Investigator may choose to follow up on information provided during this review and response period (including additional witness interviews if needed), which may lengthen this timeframe.
3. Second required review and response period following finalization of report in advance of the live hearing: 10 College business days
4. Hearing Determination: the Hearing Officer has 15 College business days following the conclusion of the live hearing to provide their written decision.
5. Appeal period: the parties have 10 College business days to submit a written appeal following the issuance of a determination letter.
6. Appeal body evaluation of appeal and issuance of written decision: The appeal body has 15 College business days to review materials and issue a written decision letter.



## **IX. Retaliation Prohibited at Jefferson College**

No person may intimidate, threaten, coerce, or discriminate against any individual for the purpose of interfering with any right or privilege under Title IX or this policy. Retaliation includes, but is not limited to, words or actions that intimidate, threaten, coerce, or discriminate against someone whole or in part because an individual has:

- Made a report or filed a complaint alleging misconduct under this policy;
- Provided information, statements, or other information for an investigation;
- Assisted in or participated in any part of the grievance or hearing process;
- Refused to participate in any part of an investigation, grievance, or hearing process; or who has
- Exercised other rights under this policy.

Note: The exercise of First Amendment/free speech rights is not considered Retaliation under this policy. Additionally, a determination of responsibility (whether that be for a finding of responsible or not responsible) does not indicate on its own that the other party (or parties) made materially false or bad faith statements.

Jefferson College will not assign policy violations that do not involve sex discrimination or Sexual Harassment but arise out of the same set of facts and circumstances as a report or complaint of sex discrimination or Sexual Harassment, for the purpose of interfering with any right or privilege secured by Title IX or this policy. Examples of this include charging a Complainant, Respondent, or Witness with underage alcohol use that may have occurred at the same time or in close proximity to the time of the reported incident of Sexual Harassment for the purpose of dissuading the individual from filing a formal complaint.

Jefferson College expects all members of our community to participate in the process of creating a safe, welcoming, and respectful environment on campus and in campus programs and activities. In particular, the College expects that Jefferson College community members will be active bystanders and will take reasonable and safe actions to prevent or stop an act of Sexual Harassment should they witness one. Taking action could include, but is not limited to, direct intervention when it is safe for one to do so, enlisting the assistance of friends or other persons to assist, and/or contacting or seeking support from person(s) in authority. Community members who choose to take these actions will be supported by the College and protected from retaliation as well as from policy violations that may have been present during the situation, such as underage alcohol use or drug use.

Complaints alleging Retaliation may be filed and will be addressed using the College's Non-Discrimination policy and procedures.

## **X. Record-Keeping Procedures**

Jefferson College will maintain for a period of at least seven years records of the following type related to the information found in this policy and procedures:

- Every Sexual Harassment investigation including any determination regarding responsibility, as well as any audio recording or transcript in accordance with federal regulations.
- Records related to disciplinary sanctions assigned to Respondents, and remedies that have been provided to a Complainant that are designed to restore or preserve equal access to educational programs or activities.
- Records related to any appeals filed and the outcome(s) of any appeals related to the processes used to resolve Sexual Harassment complaints.
- Materials used to train Title IX Coordinators, Investigators, Hearing Decision-Maker(s), and Person(s) involved in an Appeal Process at any stage of the Grievance Process (including persons involved in the decision-making or appeal process related to mandatory/discretionary complaint dismissal, emergency removal procedures, and appeals of a determination of responsibility). These training materials will be available for public inspection upon the school's website.
  - Title IX Coordinators, Deputy Title IX Coordinators, Investigators, Hearing Officers, and Appeal body members will receive training on the definition of Sexual Harassment, the scope of Jefferson College's education program or activity, how to conduct an investigation and grievance process including hearings and appeals. Training will also encompass how to serve impartially, including by avoiding prejudgment of the facts at issue, conflicts of interest, and bias.
  - Hearing Officers will receive training on any technology to be used at a live hearing and on issues of relevance of questions and evidence, including when questions and evidence about the complainant's sexual predisposition or prior sexual behavior are not relevant.
  - Investigators will receive training on issues of relevance to create an investigative report that fairly summarizes relevant evidence.

- Any materials used to train Title IX Coordinators, Deputy Title IX Coordinators, Investigators, Hearing Officers, and Appeal body members must not rely on sex stereotypes and must promote impartial investigations and adjudications of formal complaints of Sexual Harassment.
- Records related to reports of sex discrimination or Sexual Harassment along with records of any actions, including supportive measures, that were taken in response to the report or formal complaint (if a formal complaint was filed). Records must include a basis for the conclusion that the College's response was not deliberately indifferent. If no supportive measures were provided, documentation will reflect the rationale for this in light of the known circumstances.

### **XI. Confidentiality of Records**

Jefferson College will keep confidential the identity of any individual who has made a report or complaint of sex discrimination, including any individual who has made a report or filed a formal complaint of Sexual Harassment, any Complainant, any individual who has been reported to be the perpetrator of sex discrimination or Sexual Harassment, any Respondent, and any witness, except as may be permitted by the Family Educational Rights and Privacy Act (FERPA) or as required by law, or in order to carry out the purposes of this policy and procedures such as conducting any investigation, hearing, or other part of the grievance process.

## **PROHIBITION POLICY AGAINST DRUG AND ALCOHOL ABUSE**

Jefferson College intends to provide a drug free, healthful, and safe educational environment for students and other members of the College community.

The unlawful manufacture, distribution, dispensation, possession, or use of a controlled substance or alcohol on Jefferson College-owned or controlled property, or at any College-sponsored activity is expressly prohibited by the Student Code of Conduct. Violation of this policy by students will result in disciplinary action including suspension or dismissal.

In addition to College disciplinary actions, violators of this policy are also subject to civil prosecution where the offense is prohibited by state. Statutes of the State of Missouri and federal or local municipal and county governments shall take precedence over any actions taken by Jefferson College.

Student violations of this policy are to be referred to the Vice President of Student Services or other appropriate College official for disciplinary action and/or legal prosecution. College disciplinary action may be accompanied by a requirement of satisfactory attendance in a drug/alcohol abuse assistance or rehabilitation program as a condition of future attendance at the College. Jefferson College recognizes drug/alcohol dependency to be an illness presenting major health problems ranging from temporary disorientation to permanent organ damage or death. Students needing assistance in dealing with drug/alcohol dependency are encouraged to make contact with College counselors who will provide confidential assistance, information, or appropriate assistance sources in the area.

Jefferson College will inform students and employees of the College Drug and Alcohol Abuse Policy on an annual basis and provide information on community resources available to assist individuals in dealing with drug/alcohol related problems. Additionally, the College will make drug/alcohol abuse information and educational information available to members of the College community on an ongoing basis and will review its Drug and Alcohol Abuse Policy and prevention efforts biennially. Several appropriate sources of assistance are available and may be contacted directly for assistance.

- **Alcoholics Anonymous (includes Al-Anon and Al-A-Teen)**

Local meeting times and locations are available at [www.aastl.org](http://www.aastl.org)  
 St. Louis Central Services Office  
 14 Sunnen Dr. Suite 144  
 St. Louis, MO 63143  
 (314) 647-3677

- **Behavioral Health Response**

[www.bhrstl.org](http://www.bhrstl.org)  
 Talk to a counselor at any time day or night, free of charge.  
 (314) 469-6644 or (800) 811-4760 | (314) 469-3638 (TTY)

- **COMTREA (Community Treatment, Inc.)**  
Community Mental Health Center for Jefferson County  
[www.comtrea.org](http://www.comtrea.org)  
COMTREA provides alcohol and other drug abuse treatment. Family services are provided concurrently.  
227 Main Street  
Festus, Missouri 63028  
(636) 931-2700, 296-6206
- **COMTREA Medical & Dental** treatment is offered in Hillsboro and High Ridge.  
COMTREA Therapists are available for students in every public school in Jefferson County.  
4 Hickory Ridge Rd. Suite 600  
Hillsboro, MO 63050  
(636) 481-6040
- **Jefferson County Online Resource Directory**  
[www.jeffersoncountyonline.org](http://www.jeffersoncountyonline.org)  
The Community Resources Directory is a comprehensive listing of public service agencies, organizations, and other entities.
- **Mercy Hospital Jefferson**  
[www.mercy.net/practice/mercy-behavioral-health-jefferson](http://www.mercy.net/practice/mercy-behavioral-health-jefferson)  
1400 Highway 61  
Festus, Missouri 63028  
(636) 933-1000
- **Narcotics Anonymous (N.A.)**  
[www.na.org](http://www.na.org)  
P.O. Box 771908  
St. Louis, MO 63177  
(314) 830-3232
- **Hyland Behavioral Health Center**  
[www.mercy.net/practice/hyland-behavioral-health-center](http://www.mercy.net/practice/hyland-behavioral-health-center)  
10010 Kennerly Road  
St. Louis, Missouri 63128  
(314) 525-4400

## ACADEMIC COMPUTER USE POLICY

### PURPOSE

As part of its educational mission, Jefferson College strives to provide quality computing facilities, whether through technology available in classrooms and labs, or available for checkout through the Jefferson College Library. Each computer user is responsible for use of the computing resources in an effective, efficient, ethical, and lawful manner. Please note that computing at Jefferson College is a privilege, not a right. Each individual is responsible for selecting, viewing, and utilizing appropriate resources and avoiding excessive use of the system that could interfere with other College purposes. It is the objective of Jefferson College to maintain an atmosphere of constructive learning, academic freedom, and proper asset management and control. The following policies and practices are intended to be helpful in the appropriate use of Jefferson College's technology resources.

### USER ELIGIBILITY

All users must adhere to the Jefferson College Academic Computer Use Policy. Academic use of computer labs and classrooms will have priority use of computing resources. Non-class users may be asked to leave during academic use of these areas. Users may be asked to show a photo ID and/or sign in to use a campus computer. Sign in data is used to generate usage reports to determine staffing needs.

Please note that, using a computer to review what may be considered pornographic or obscene material violates Student Code of Conduct, III, Behavioral Misconduct, as outlined on page 16 in this handbook. Misuse of computers, including but not limited to, creating an “offensive educational environment” and “causing a disturbance or nuisance in the computer lab” violates Student Code of Conduct, II, Interference with the Educational Mission of the College, as outlined on page 17 in this Student Handbook.

Community members who would like to use a campus computer lab should contact a Library employee or lab supervisor. Approval will be based on availability of computers and an agreement to abide by the policies.

## **GENERAL GUIDELINES**

Access to computing resources is contingent upon prudent and responsible use. Inappropriate use of computing services and facilities will not be tolerated and may result in loss of computing privileges. In addition, disciplinary and/or legal action will be pursued for violation of these codes and statutes through appropriate procedures. To obtain additional information regarding procedures and additional sanctions, which includes information on what may be considered pornographic or obscene material that violate the Student Code of Conduct, III, Behavioral Misconduct, students should refer to the Student Code of Conduct found on page 16 in this handbook.

All computer users are expected to observe ethical behavior in the use of College equipment and services. Examples of inappropriate behavior include the following:

- Wasting limited resources, such as excessive printing or printing multiple copies
- Disproportionately using computing resources
- Altering, changing, or deleting hardware and software configurations
- Loading unlicensed applications/program software onto lab computers
- Simultaneously using multiple computers
- Using College computing facilities for commercial purpose
- Interfering in any way with another’s use of College equipment or services
- Causing a disturbance or nuisance in the computer lab

Examples of unacceptable, zero tolerance behavior include the following:

- Knowingly introducing a computer virus or other destructive program
- Creating, disseminating, or possessing pornography
- Possessing or using programs, files, or instructions for violating system security
- Intimidating or creating an atmosphere of harassment based upon age, ancestry, color, creed, disability, genetic information, marital status, national origin, race, religion, sex, gender identity or expression, sexual orientation, or veteran status
- Creating an “offensive educational environment”

College employees have the authority to revoke computer lab privileges for any person engaged in inappropriate or unacceptable use of the computer lab. Disregard of any warnings issued or sanctions made will result in referral to the Vice President of Student Services for disciplinary action. Non-students/employees (community members) in violation of computer use policy will be referred to the appropriate supervisor or Campus Police.

No person may use College computing resources to violate any state or federal laws. Such actions will result in notification of the appropriate authorities. Examples of illegal use include the following:

- Creating, disseminating, or possessing child pornography
- Violation of copyright law (i.e. making illegal copies of copyrighted material. Such materials may include software, movies, music. For example, peer-to-peer file sharing is often used illegally)
- Fraudulent, threatening, or obscene e-mail, graphics, or other electronic communications
- Unauthorized entry into secure web sites or servers

Misuse of computers, including but not limited to, creating an “offensive educational environment” and “causing a disturbance or nuisance in the computer lab” violates Student Code of Conduct, II, Interference with the Educational Mission of the College, as outlined on page 17 in this Student Handbook.



## **RESPONSIBILITY**

Jefferson College and its employees are not liable for any damages and/or losses associated with the use of any of its computer resources or services or incurred by loss of service. Users are encouraged to save often to removable media, not the computer.

**NOTE:** The terms lab, computer lab(s), and campus computer lab also refer to the computers in the Library at all Jefferson College locations. The term community member(s) also refers to Community Borrowers or any library user.

## **CELL PHONE USE IN CLASSROOMS**

As a member of the learning community, each student has a responsibility to other students who are members of the community. When cell phones ring and students respond in class or leave class to respond, it disrupts the class. Jefferson College prohibits the use by students of cell phones or similar communication devices during scheduled classes. All such devices must be turned off or put in a silent (vibrate) mode and ordinarily should not be taken out during class. Given the fact that these same communication devices are an integral part of the College's emergency notification system, an exception to this policy would occur when numerous devices activate simultaneously. When this occurs, students may consult their devices to determine if a College emergency exists. If that is not the case, the devices should be immediately returned to silent mode and put away. Other exceptions to this policy may be granted at the discretion of the instructor.

Sanctions for violation of this policy are determined by the instructor and may include dismissal from the class.

## **OFFICIAL STUDENT RECORDS**

Official records are maintained on each student enrolled in the College. Procedures for development and use of cumulative record files are written to comply with the Family Educational Rights and Privacy Act of 1974 as amended. Information placed in student records is limited to those items necessary to fulfill the purpose of student records as stated above or as may be required by law, by state regulation, or as authorized by the Board of Trustees.

## **NOTIFICATION OF RIGHTS UNDER FERPA**

The Family Educational Rights and Privacy Act of 1974 as amended (FERPA) affords students certain rights with respect to their education records. They are:

1. The right to inspect and review the student's education records within 45 days of the day the College receives a request for access. Students should submit to the Registrar, Dean, or other appropriate official, written requests that identify the records they wish to inspect. The College official will make arrangements for access and notify the student of the time and place where the records may be inspected. If the records are not maintained by the College official to whom the request was submitted, that official shall advise the student of the correct official to whom the request should be addressed.
2. The right to request the amendment of the student's education records that the student believes are inaccurate or misleading. Students may ask the College to amend a record that they believe is inaccurate or misleading. They should write the College official responsible for the record, clearly identify the part of the record they want changed, and specify why it is inaccurate or misleading. If the College decides not to amend the record as requested by the student, the College will notify the student of the decision and advise the student of their right to a hearing regarding the request for amendment. Additional information regarding the hearing procedures will be provided to the student when notified of the right to a hearing.
3. The right to consent to disclosures of personally identifiable information contained in the student's education records, except to the extent that FERPA authorizes disclosure without consent. One exception which permits disclosure without consent is disclosure to school officials with legitimate educational interest. A school official is a person employed by the College in an administrative, supervisory, academic or research, or support staff position (including law enforcement unit personnel and health staff); a person or company with whom the College has contracted (such as an attorney, auditor, or collection agent); a person serving on the Board of Trustees; or a student serving on an official committee, such as a disciplinary or grievance committee, or assisting another school official in performing their tasks. A school official has a legitimate educational interest if the official needs to review an education record in order to fulfill their professional responsibility.

As of January 3, 2012, the U.S. Department of Education’s FERPA regulations expanded the circumstances under which students’ education records and personally identifiable information (PII) contained in such records — including the student’s Social Security Number, grades, or other private information — may be accessed without the student’s consent. First, the U.S. Comptroller General, the U.S. Attorney General, the U.S. Secretary of Education, or state and local education authorities (“Federal and State Authorities”) may allow access to the student’s records and PII without the student’s consent to any third party designated by a Federal or State Authority to evaluate a federal- or state-supported education program. The evaluation may relate to any program that is “principally engaged in the provision of education,” such as early childhood education and job training, as well as any program that is administered by an education agency or institution. Second, Federal and State Authorities may allow access to the student’s education records and PII without the student’s consent to researchers performing certain types of studies, in certain cases even when we object to or do not request such research. Federal and State Authorities must obtain certain use-restriction and data security promises from the entities that they authorize to receive the student’s PII, but the Authorities need not maintain direct control over such entities. In addition, in connection with Statewide Longitudinal Data Systems, State Authorities may collect, compile, permanently retain, and share without the student’s consent PII from the student’s education records, and they may track the student’s participation in education and other programs by linking such PII to other personal information about the student that they obtain from other Federal or State data sources, including workforce development, unemployment insurance, child welfare, juvenile justice, military service, and migrant student records systems.

Jefferson College may make available to the public the following directory information: name, address, telephone number, date of birth, Jefferson College e-mail address, dates of attendance at Jefferson College, full or part-time enrollment status, major area of study, participation in officially recognized sports, degrees or certificates awarded, awards received, photograph, and the most recent prior school attended. Additionally, students are included in graduation lists, dean’s lists, and enrollment lists to the military. If the student objects to the release of directory information, the student should contact the Office of Enrollment Services before beginning classes. New and returning students are advised that the social security number is voluntarily disclosed and is maintained as confidential information.

4. The right to file a complaint with the U.S. Department of Education concerning alleged failures by the College to comply with the requirements of FERPA. The name and address of the office that administers FERPA are: Family Policy Compliance Office; U.S. Department of Education; 400 Maryland Avenue, SW; Washington, DC 20202-5920.

Any other records shall be of a temporary nature and shall be destroyed when their usefulness is no longer apparent or when the student leaves the College. Guidelines for periods of retention and methods of destruction are consistent with state and national standards.

## **STUDENT APPEAL PROCESS FOR MISAPPLICATION OF COLLEGE POLICIES, PROCEDURES, & PRACTICES**

A Jefferson College student may appeal any instance of misapplication of College policy, procedure, or practice which adversely affects them. Under this process, the student may not appeal the following:

- A. The receipt of a grade or academic sanctions; or
- B. Established College policies or procedures; or
- C. The outcome of procedures that already include appeal processes such as the Student Code of Conduct, the Non-Discrimination and Complaint Procedure, or the Title IX Sexual Harassment Procedure and Grievance Process.

The College Student Appeal Process provides the student due process in the resolution of appeals. Where a specific College process is provided for resolution of a complaint, it must be used. The decision shall be final if the student fails to employ the steps and time periods of the Student Appeals Process.

A student who alleges that they have been adversely affected by the misapplication of College policy, procedure, or practice shall first meet informally with the person applying the policy, procedure, or practice to discuss the situation in an attempt to reach an informal resolution. If this meeting does not resolve the situation, the following process of appeal shall be used if any appeal is filed:

1. The student shall, within five class days of knowledge of the circumstance, submit written material to the College

official who allegedly misapplied College policy, procedure, or practice. The written materials should indicate that a formal appeal of the issue is being initiated, request reconsideration, explain the situation being appealed, the basis for the appeal, including the policy, procedure, or practice, and produce any written evidence. The student and employee of the College shall meet within two class days after receipt of the materials. The employee shall provide the student a written decision within two class days following the meeting.

2. If the initial formal decision is adverse to the student, they may appeal the decision to the employee's immediate supervisor within five class days thereafter except if the immediate supervisor is a senior College official, the process moves to paragraph three.

The supervisor will be provided copies of all previously considered materials from the student and written materials from the employee on which the earlier decision was based. The supervisor will review all supporting materials submitted as well as any other relevant materials and will meet with student and employee within five class days thereafter to further discuss and clarify the issue at question. The supervisor will render a written decision to student and employee within five class days thereafter to further discuss and clarify the issue at question. The supervisor will render a written decision to student and employee within two further class days. The student may appeal the decision of the supervisor to the Student Appeals Committee within two class days after receipt of the decision on written notice to the College President.

3. The Student Appeals Committee shall be composed of two students appointed by the student government president, two faculty, and one each of classified professional and certified professional employees all appointed by the College President. No committee members may have a material interest in or knowledge of the issue on appeal. The Student Appeals Committee shall receive for review and information all written materials relevant to the appeal which will be independently reviewed by committee members. The committee may collect additional information it deems necessary to rule on the question. The Student Appeals Committee will schedule a meeting on the appeal after written materials have been reviewed and invite the appealing student and College employees earlier involved in the appeal process to present evidence and clarify any of the written materials. Other parties may be invited by the Student Appeals Committee to speak with it if necessary. Committee members may question all participants regarding written or verbal statements. The committee may select its own chair, devise its own rules, may limit discussion, and otherwise conduct the meeting as it deems fair and appropriate.

4. The Student Appeals Committee will make its recommendation in writing on the dispensation of the appeal to the appropriate senior level College official. The senior official will review the committee recommendation and all supporting documents with the committee chair. The committee's recommendation is advisory, and the senior official will render a written decision on the appeal to all involved parties within five class days of receipt of the committee recommendation. The decision on the appeal at this level is final.

## **AVAILABILITY OF FEDERAL DISCLOSURE INFORMATION**

*Required by the Family Educational Rights and Privacy Act (FERPA) of 1974*

The following documents are available for viewing, downloading, or printing from the College web site by following this link ([www.jeffco.edu](http://www.jeffco.edu): click "About," click "General Information," click "Consumer Information").

Direct link: [www.jeffco.edu/current-students/information/consumer-information](http://www.jeffco.edu/current-students/information/consumer-information).

Hard copies are also available upon request from the office listed for each item.

1. Notice of Availability of Institutional and Financial Aid Information: Lists availability of financial aid, steps to apply, and costs of attending and estimated budgets. Student Loans: Lists information about Federal Direct Loans, including Repayment Information. Printed information is available from the Office of Financial Aid, located on the first floor of the Student Center, (636) 481-3212.

2. College General Catalog: Contains current academic and career-technical degree and training programs; course descriptions; instructional, lab, and related physical facilities; faculty and instructional personnel listing; names of accrediting, approving, and licensing bodies; student withdrawal and tuition refund policies; and much more. Copies are available from the Office of Enrollment Services, first floor of the Student Center, (636) 481-3209.

3. Student Refund Policies: Summarizes refund policies and procedures and return of Title IV grant/loan assistance. Policies are located in the College General Catalog and related information is available in the brochure titled Federal

Overpayment Policy. Printed copies are available from the Office of Financial Aid, located on the first floor of the Student Center, (636) 481-3212.

4. Facilities and Services for Students with Disabilities: The Disability Support Services Manual contains a listing of special facilities and services available for students with disabilities. Copies are available from the Office of Disability Support Services located in the Technology Center, (636) 481-3158.
5. Completion, Transfer, and Retention Rates: Contains completion, transfer, and retention rate information for first-time, full-time, degree-seeking students and athletic program participation rates. Copies are available from the Office of Institutional Research, located in the Technology Center, Room 201A, (636) 481-3210.
6. Annual Security and Fire Safety Report (Clery Act): Contains required security policies and procedures, titles of Campus Security Authorities, and crime statistics. Copies are available from the Jefferson College Police Department (JCPD) Office, 802 Mel Carnahan Drive, Apartment 214, Hillsboro, MO 63050; JCPD Office, Jefferson College Arnold, 1687 Missouri State Road, Arnold, MO 63010; or Administration Office, Jefferson College Imperial, 4400 Jeffco Boulevard, Arnold, MO 63010; (636) 481-3500.
7. Daily Crime Log: Records criminal incidents and alleged criminal incidents that are reported to the Jefferson College Police Department (JCPD). This log is available for viewing in the Police Department Office, 802 Mel Carnahan Drive, Apartment 214, Hillsboro, MO 63050; JCPD Office, Jefferson College Arnold, 1687 Missouri State Road, Arnold, MO 63010; or Administration Office, Jefferson College Imperial, 4400 Jeffco Boulevard, Arnold, MO 63010; (636) 481-3500.
8. Equity in Athletics Disclosure Act Report: Contains summary information of total operating expenses and revenues for men's and women's sports and other required supporting data for the athletic program. Copies are available from the Office of the Director of Athletics, Field House, (636) 481-3386.
9. Privacy of Student Records (FERPA): This document is the College's policy statement assuring the privacy and practices for safeguarding student personal information. Copies are available from the Office of Enrollment Services, located on the first floor of the Student Center, (636) 481-3209.
10. Drug-Free Schools and Campuses Regulation (EDGAR Part 86): Notifies all employees and students of the College's alcohol and other drug prevention policies. These policies include the following: (1) standards of conduct; (2) possible legal sanctions and penalties; (3) statements of the health risks associated with alcohol and other drug abuse; (4) alcohol and other drug prevention programs available to students, staff, and faculty; and (5) disciplinary sanctions for violations of the standards of conduct. Copies are available from the Student Compliance Department, located on the top floor of the Student Center, (636) 481-3258.
11. Notice of Potential Use of Student Data for Academic Research: All Jefferson College students are advised that their academic data may, subject to federal privacy (FERPA) and research laws (45 CFR 46), be accessed for the purposes of academic research. This may be reported out in order to meet the requirements of federal or state reporting laws, or it may be used to support appropriate academic research. In all such cases, no published data or reports will include information specific to any individual student.

## **MINIMUM STANDARDS OF ACADEMIC PROGRESS**

All students must meet guidelines regarding academic progress. Students receiving financial aid must meet additional requirements.

### **ACADEMIC PROBATION, SUSPENSION, AND READMISSION GUIDELINES**

Each student is expected to make minimum academic progress while enrolled at Jefferson College. A student is considered to be making minimum progress if they maintain a cumulative grade point average (GPA) of at least 2.0. A student whose progress falls below minimum requirements shall be placed on academic probation. The student will be notified of the probationary status and informed of resources available for academic improvements.

If the student's cumulative grade point average remains below 2.0 at the end of the probationary semester, the student will be



placed on academic suspension and will not be allowed to enroll or remain in classes for subsequent semesters. The student must appeal the suspension if they wish to enroll in subsequent semesters. Information regarding the academic suspension appeal process and procedure is available in the Office of the Vice President of Student Services.

## **FINANCIAL AID GUIDELINES**

Financial aid is intended to assist students as they make successful progress towards completing a degree. Therefore, financial aid recipients must demonstrate satisfactory academic progress. In turn, the U.S. Department of Education mandates that Jefferson College define, establish, and enforce minimum standards of satisfactory academic progress for students receiving financial assistance.

The College's satisfactory academic progress (SAP) policy is based upon cumulative progress, including non-degree and degree hours attempted. It applies equally to new, continuing, and transfer students. There are several factors that affect satisfactory academic progress and a student's eligibility to participate in the financial aid programs administered by Jefferson College.

### **❖ GRADES**

Successful completion is defined as receiving a grade of A, B, C, or D.

A grade of "F" (Failure), "W" (Student-Initiated Withdrawal), "WX" (Administrative Withdrawal), "H" (Audit), or "I" (Incomplete) is considered unsatisfactory. All coursework must be completed within the regular semester time frame.

Although the College allows a student to take an Incomplete grade in a course and complete the course in the following semester, the course was not completed in the specified time frame, and the grade is therefore unsatisfactory for financial aid purposes. Students who wish to Audit a course must declare this intent prior to the start of the course, as this course is not part of the degree program.

#### **Is it better to withdraw or take an F?**

This is a frequently asked question. A "W" will not affect the grade point average, but it will adversely affect the attempted vs. earned ratio. A grade of "F" will negatively affect both. It is advisable to consult with the Financial Aid Office to assist with this decision.

### **❖ GRADE POINT AVERAGE**

Financial aid recipients are required to maintain a cumulative grade point average of 2.0 or above.

### **❖ HOURS ATTEMPTED VS. HOURS EARNED**

Students must complete a cumulative total of 67% of all coursework attempted, including degree and remedial coursework within all parts of term. Coursework attempted during all semesters, including fall, spring, and summer, will be evaluated. Transfer credit accepted from other colleges and universities will be included in the number of credit hours attempted and earned.

#### ***Example:***

In the fall, Jane Doe attempted 15 credit hours and completed nine. She withdrew from two, three-credit hour courses. Jane completed 60% of the coursework she attempted. This is below the minimum standard of 67%. Therefore, Jane is on financial aid warning going into the spring semester. While on warning, she can continue to receive financial aid. However, she must carefully consider the number of credit hours she attempts in the spring.

In the spring, Jane attempts nine credit hours and completes all of them. Now, her cumulative record shows that she has attempted 24 and completed 18. She has improved her standing and now has completed 75% of all coursework she has attempted. Now Jane is back in good standing and removed from financial aid warning.

However, if Jane did not improve her attempted vs. earned ratio at the end of the spring semester, she would have been placed on financial aid suspension and, therefore, ineligible to receive financial aid in future semesters, unless she successfully appeals her suspension.

## ❖ **MAXIMUM TIME LIMITS**

Financial aid recipients must complete their specified degree program within 150% of the published length of the academic program.

For example, if the hours required for the Associate of Arts (AA) degree is 62 credit hours, the maximum hours allowed for an AA degree-seeking student would be 93 credit hours. See the “Minimum Standards of Academic Progress” brochure issued by Financial Aid for each program’s maximum hours allowed.

In addition, if a student previously graduated with a degree from Jefferson College, they may be suspended from receiving financial aid, if no longer degree-seeking.

Also, the U.S. Department of Education will not permit the College to issue financial aid for coursework not required for completion of the student’s declared program at that school. Please confirm with the Office of Enrollment Services that all courses for which you are registered are needed for completion of your program of study.

## **WHAT HAPPENS IF I FAIL TO MEET MINIMUM STANDARDS OF SATISFACTORY ACADEMIC PROGRESS FOR FEDERAL FUNDS?**

### ❖ **FINANCIAL AID WARNING**

Students may continue to receive assistance for one additional semester, but must regain satisfactory academic progress by the end of the warning semester or aid will be suspended.

### ❖ **FINANCIAL AID SUSPENSION**

Continued failure to meet satisfactory academic progress will result in financial aid suspension. Financial aid suspension means the termination of all federal and state financial aid.

### ❖ **CAN I GET FINANCIAL AID FUNDS REINSTATED?**

A student may regain eligibility to participate in the financial aid program once the minimum standards of academic progress have been reached.

### ❖ **STUDENT’S RIGHT TO APPEAL FINANCIAL AID SUSPENSION**

In the event of extenuating circumstances, a student on financial aid suspension may request to be continued in the financial aid program through a written appeal submitted with appropriate documentation to Financial Aid. The Financial Aid Appeals Committee will review all written appeals and notify the student of the results. Further instructions related to the appeal process will accompany the letter of suspension.

### ❖ **EXCEEDED MAXIMUM TIME FRAME APPEALS**

To assist individuals pursuing a second career or working toward a new program of study, students who have reached their maximum hour limits are permitted to appeal to continue on an academic plan that extends their time frame for financial aid eligibility.

### ❖ **FINANCIAL AID PROBATION**

If a student’s financial aid appeal is approved, the student will be placed on financial aid probation. A student placed on probation may continue to receive aid as long as the student meets the conditions of their academic plan. At minimum, the student’s Financial Aid Probation Academic Plan requires a student complete 100% of all coursework attempted each term with a minimum grade point average of 2.0. Additional conditions are listed in each student’s plan. Failure to meet the conditions of the financial aid probation will result in loss of financial aid eligibility.

# **U.S. DEPARTMENT OF EDUCATION RETURN OF TITLE IV FUNDS POLICY**

Students who have been paid federal financial aid funds are required to earn these funds by attending classes through at least 60% of the period of enrollment. Students who quit attending or withdraw from all courses, but have already received their federal financial aid disbursement for the semester, may have been overpaid. If an overpayment occurs, the student is required to repay a portion of the funds to the school and to the U.S. Department of Education.

## **❖ WHICH FINANCIAL AID FUNDS ARE AFFECTED?**

The federal repayment policy affects students who have received assistance through the following federal financial aid programs:

- ❖ Pell Grant
- ❖ Supplemental Education Opportunity Grant (SEOG)
- ❖ Federal Direct Subsidized and Unsubsidized Loans
- ❖ Parent (PLUS) Loans

## **❖ HOW IS THE OVERPAYMENT AMOUNT DETERMINED?**

The overpayment amount is based upon the number of days in the semester the student completed. The more days the student has been in attendance, the less the overpayment. A federally mandated formula is used to calculate the amount of the overpayment.

## **❖ HOW DOES THE SCHOOL DETERMINE MY LAST DATE OF ATTENDANCE?**

When determining a last date of attendance and calculating the portion of funds earned by the student, the institution must always use the student's last date of an academically-related activity as indicated in official attendance records of the College and reported by faculty. A documented last date of attendance based on an academically-related activity must be used to determine a student's unofficial withdrawal date. Furthermore, a documented last date of attendance based on an academically-related activity must also be used to determine the portion of aid earned by those students who officially withdraw from courses.

## **❖ WHAT IF I FAIL TO BEGIN ATTENDANCE IN A COURSE?**

Federal regulations require that students earn their financial aid funds by attending courses. If a student fails to begin attendance in a course, the school is required to reduce the student's financial aid enrollment level and eligibility. If a student is not attending classes, the student is expected to complete the official withdrawal process of the College. To complete the withdrawal process, contact the Office of Enrollment Services located in the Student Center.

## **❖ WILL I BE AFFECTED IF I WITHDRAW FROM AN INDIVIDUAL COURSE?**

This policy only applies to students who:

- Withdraw from or cease attendance in all classes prior to the 60% point of the semester.
- Fail all classes and cease attendance prior to the 60% point of the semester.

*It does not apply to a student who has withdrawn from selected courses.*

## **❖ DO I SEND THE AMOUNT OF MY OVERPAYMENT TO THE SCHOOL OR TO THE U.S. DEPARTMENT OF EDUCATION?**

If an overpayment of federal financial aid occurs, the student may be required to return a portion of the overpayment to the school and to the U.S. Department of Education. The College will return the overpayment to the U.S. Department of Education on the student's behalf and bill the student for the balance due, allowing 45 days for repayment. Any unpaid balance due to the school will be subject to collection action.

Students may not use the next semester's financial aid award to pay a past due balance incurred during a different loan period or financial aid award year.

## **❖ WHEN WILL I KNOW IF I HAVE TO RETURN AN OVERPAYMENT?**

The College reviews all student attendance and official withdrawal information throughout each semester. If a student is required to repay all or a portion of their financial aid, the amount will be posted to the student's Jefferson College account and written communication accompanying a bill will be mailed.

**This policy only applies to students who withdraw from all courses or students who stop attending all classes.**

## ❖ HOW CAN I AVOID GETTING INTO A SITUATION THAT WILL REQUIRE THE RETURN OF AN OVERPAYMENT?

Many students panic when they begin to struggle in classes. They will withdraw from all classes even though they may be doing well in one or two classes. Students should only withdraw from those classes that are giving them the most difficulty and attempt to finish as many classes as possible.

### **\*\* IMPORTANT NOTICE \*\***

*Students verified to receive any form of federal, state, or institutional financial aid are prevented from being dropped from courses for non-payment. A student's financial aid counts as anticipated payment, so if a student is not planning to attend the College, the student must officially drop all classes within the refund period, or the student may be held responsible for the semester's charges.*

## **CLASS ATTENDANCE POLICY**

Regular and punctual attendance is expected of all students. Students are not entitled to a certain number of absences; information presented in the classroom is critical in the learning process. Any one of these four options may result in the student being removed from the class and an administrative withdrawal being processed:

- Student fails to begin attendance
- Student ceases participation for at least two consecutive weeks
- Student misses 15 percent or more of the coursework
- Student misses 15 percent or more of the course as defined by the instructor

Individual programs may have more rigorous attendance and participation requirements. Jefferson College is an attendance taking institution. Weekly attendance reporting is required. At the beginning of the semester, the instructor will notify their students of the attendance and punctuality requirements for the class. Students earn their financial aid by regularly attending and actively participating in their coursework, whatever the delivery method of the course. Online courses also require regular, active participation as attendance. If a student does not actively participate, they may have to return financial aid funds. Consult the Office of Financial Aid for more details.

## **ADMINISTRATIVE WITHDRAWAL**

Any student who fails to begin attendance or ceases participation for at least two consecutive weeks may be administratively withdrawn from the course(s). Additionally, any student who has sporadic participation in a course resulting in the student missing 15% or more of the coursework may be administratively withdrawn. Individual programs may have more rigorous attendance and participation requirements.

Any student who feels that the administrative withdrawal was executed unfairly or inaccurately can appeal the withdrawal within 10 calendar days of notification. The student must submit a written letter of appeal to the appropriate associate dean or director. A student who is administratively withdrawn will receive a grade of "WX" for the course(s) and will be financially responsible for all tuition and fees associated with the course(s).

An administrative withdrawal may only be granted through the official College withdrawal deadline for each course(s).

## **FINANCIAL AID IMPLICATIONS RELATED TO ATTENDANCE**

Federal regulations require that students earn financial aid funds by attending and participating in courses. If a student fails to begin attendance in a course, the institution is required to reduce the student's financial aid enrollment level and eligibility. Also, a last date of attendance based on an academically-related activity must be used to determine the portion of financial aid earned by those students who officially and unofficially withdraw from all courses. See the "Federal Overpayment Policy" brochure issued by Financial Aid for additional details.



# **WITHDRAWING, DROPPING, AND ADDING COURSES**

A student is officially a member of each course in which they have enrolled. To add, drop, or withdraw from a course, a student must complete and submit the appropriate paperwork at one of the Jefferson College locations by the designated date or complete the add, drop, or withdrawal process online. Deadlines for adding, dropping, or withdrawing from a course vary based on the length of the course and are available on the Jefferson College website. Students who have not paid, or made arrangements to pay tuition, may be subject to drop for non-payment.

## **REQUEST FOR MEDICAL WITHDRAWAL**

If a student becomes seriously ill or critically injured and is physically unable to continue attending or participating in their classes, the student should withdraw from classes to avoid receiving failing grades. If the illness or injury occurs after the published withdrawal deadline has passed, a student may then submit a Request for Medical Withdrawal. For specific withdrawal dates for all courses, visit the Jefferson College website at [www.jeffco.edu](http://www.jeffco.edu). Financial aid recipients should contact the Financial Aid Office prior to withdrawing from classes to discuss how their financial aid status/eligibility may be affected.

The Request for Medical Withdrawal form is available under the Student tab in MyJeffco, and can also be obtained from the Vice President of Student Services Office, the Office of Enrollment Services, or at Jefferson College Arnold or Jefferson College Imperial.

### ***Please note:***

A medical withdrawal will not generate a refund of tuition charges and/or lab fees paid, nor will it remove a balance for assessed tuition charges and/or lab fees. A “W” grade will be posted on a student’s transcript for each withdrawn course, and the course(s) will count into attempted credit hours for financial aid purposes.

## **GRADE APPEAL PROCESS**

1. If a student believes that a final grade for a course is not correct, the student should contact the instructor of record to determine why that grade was assigned. This communication may be conducted in person, in writing, or through electronic communication. This question should be asked as early as possible to allow for a rapid resolution of any administrative or clerical errors.
2. If no answer is received by the start of the next regular semester (Fall or Spring), or if the instructor’s response is not satisfactory, the student may initiate a formal grade appeal. The deadline for initiating a formal grade appeal is the first business day of the second week of the next regular semester (Fall or Spring). The student will contact the instructor by e-mail using an official Jefferson College account. The student will copy the message to the instructor’s Associate Dean (or designated institutional supervisor). The message must include the student’s full name, the CRN of the course (five-digit course registration number), the nature of the disagreement, and the student’s calculation of their final grade based on the course syllabus.
3. It is then the responsibility of the instructor to explain, making explicit references to the course syllabus, the determination of the course grade. That information will be sent to the student through an official Jefferson College e-mail account. The instructor’s Associate Dean (or designated institutional supervisor) will be copied on that message. The instructor has five business days after receiving the formal grade appeal to respond to it.
4. If the response provided by the instructor is deemed by the student to be insufficient, or if the student has not received a reply after five business days, the student may appeal the instructor’s decision to the appropriate Associate Dean (or designated institutional supervisor). This must be initiated no later than 10 business days after the initial request for a formal grade appeal. The correspondence should be made through a Jefferson College e-mail account.
5. The appeal of the instructor’s decision going to the Associate Dean (or designated institutional supervisor) should include the nature of the grade disagreement, a copy of communication between the student and the instructor, and a copy of the course syllabus. The Associate Dean (or designated institutional supervisor) then has five business days to investigate the issue and to transmit a response to the student through a Jefferson College e-mail account.

6. If the response provided by the Associate Dean (or designated institutional supervisor) is deemed by the student to be insufficient, or if the student has not received a reply within five business days, the student may appeal the decision of the Associate Dean (or designated institutional supervisor) to the Dean of Instruction. This should be initiated no later than 20 business days after the initial request for a formal grade appeal. The correspondence should be made through a Jefferson College e-mail account.
7. The Dean of Instruction will receive the same documentation provided to the Associate Dean (or designated institutional supervisor), with the additional inclusion of the response of the Associate Dean (or designated institutional supervisor). The Dean of Instruction then has five business days to investigate the issue and to transmit a response to the student through a Jefferson College e-mail account.
8. If the response provided by the Dean of Instruction is deemed by the student to be insufficient, or if the student has not received a reply within five business days, the student may appeal the decision of the Dean to the Vice President of Instruction (or designated institutional supervisor). This should be initiated no later than 25 business days after the initial request for a formal grade appeal. The correspondence should be made through a Jefferson College e-mail account.
9. The Vice President of Instruction will receive the same documentation provided to the Dean of Instruction, with the additional inclusion of the response of the Dean. The Vice President of Instruction then has five business days to investigate the issue and to transmit a response to the student through a Jefferson College e-mail account.
10. The determination of the Vice President of Instruction is final.  
 Note: In the event that an appropriate individual is unavailable to resolve the grade dispute during the designated time frame or there is a conflict of interest, Jefferson College will designate an appropriate institutional peer.

## CAMPUS WHO'S WHO

Extensions are listed; to reach the contact, dial (636) 481-XXXX.

**Dr. Dena McCaffrey**, *President*, ext. 3100

**Mr. Daryl Gehbauer**, *Vice President of Finance and Administration*, ext. 3120

**Dr. Kim Harvey-Manus**, *Vice President of Student Services*, ext. 3200

**Dr. Chris DeGeare**, *Vice President of Instruction*, ext. 3300

**Dr. Josephine Kershaw**, *Dean of Instruction*, ext. 3400

**Dr. Michael Booker**, *Associate Dean of Humanities*, ext. 3312

**Dr. Terry Kite**, *Associate Dean of Business, Social Sciences & Public Services*, ext. 3373

**Ms. Maryanne Angliongto**, *Associate Dean of Math, Physics & Technology*, ext. 3318

**Dr. Kenny Wilson**, *Associate Dean of Science & Health*, ext. 3356

## FACULTY OFFICE HOURS

For information regarding faculty office hours, go to the College website ([www.jeffco.edu](http://www.jeffco.edu)) and log in to MyJeffco; under the Student tab, choose the Faculty Office Hours button. You may also go directly to [jeffco.edu/Faculty-Office-Hours](http://jeffco.edu/Faculty-Office-Hours).

## JEFFERSON COLLEGE DRUG-FREE WORK PLACE GUIDELINES

Jefferson College makes every effort to provide a positive learning and working environment. In keeping with this philosophy, the College promotes a drug-free work place and condemns the improper use of narcotics, dangerous or illegal drugs, or intoxicants which substantially impair the individual's performance.

It is the desire of the College to provide a wholesome and productive environment for both employees and students. If you experience a drug or alcohol-related problem, or become aware of a member of the College community with such a problem,

we encourage you to attempt to facilitate a referral of this person for assistance to College or appropriate community treatment agencies or resources. The College intends to provide information on services that are available without endorsing any institutional or treatment procedure.

Jefferson College prohibits the unlawful possession, use, or distribution of drugs and alcohol by students and employees on its property or as any part of its institutional activities. Health risks associated with the use of illicit drugs and the abuse of alcohol range from temporary disorientation to permanent organ damage or death. The College will impose sanctions on students and employees, up to and including expulsion from College or termination of employment, and referral for prosecution for violations of the College standards of conduct. Weapons or guns of any type are prohibited on the Jefferson College campus.

## **AGREEMENT FOR SUCCESS**

At Jefferson College, we believe that the seeds of greatness are in each student. It is through education that the gifts and talents in each student are realized. Faculty, staff, and students have complementary and mutual responsibilities to assure student success. The purpose of this agreement for success is to describe those mutual responsibilities.

### **AS A FACULTY OR STAFF MEMBER OF JEFFERSON COLLEGE:**

- I will treat students with courtesy and respect and expect the same.
- I will have high expectations for each student.
- I will encourage each student to become all that they are capable of becoming.
- I will value time, start and end classes on time, and set priorities for the use of time.
- I will be enthusiastic about my work. I will strive to stay current in my field and find creative ways to teach my subject in a manner that is interesting and relevant to students' educational goals.
- I will clearly describe the expectations in my class and provide students with feedback on the accomplishments of their achievements.
- I will not label students and will display a willingness to discuss options and goals that students are willing to work hard to achieve.
- I will respect differences among members of the campus community and encourage everyone to learn from these differences.
- I will be honest and maintain the highest level of integrity.

### **AS A STUDENT OF JEFFERSON COLLEGE:**

- I will treat faculty and staff with courtesy and respect and expect the same.
- I am responsible for my education. While others may help me, my success will depend primarily upon what I do to become successful. If it is to be, it is up to me.
- I will work hard to succeed. This includes attending all classes and devoting a great deal of time to reading, studying, and doing out-of-class assignments.
- I will spend the appropriate time needed in outside preparation for each hour of class time.
- I will value time, come to classes on time, and be attentive and participate.
- I will set positive, specific, and measurable goals, and I will visualize myself in possession of them.
- I will be an active learner. I will ask questions and seek guidance as often as needed and within the capacity of the faculty/staff member.
- I will respect differences among members of the campus community and encourage everyone to learn from these differences.
- I will be honest and maintain the highest level of integrity.

FALL 2022		SPRING 2023	
August 4-7	Technology Maintenance (Canvas and online services may not be available)	January 16	Martin Luther King Day (campus closed)
August 22	Classes Begin	January 17	Classes Begin
September 2	14-week Classes Begin	January 24	Faculty In-Service Day (no day or night classes)
September 3	Labor Day recess begins, 7:00 a.m.	January 30	14-week Classes Begin
September 6	Labor Day recess ends, 7:00 a.m.	February 4	14-week Saturday Classes Begin
September 10	14-week Saturday Classes Begin	February 20	President's Day (campus closed)
October 12	First short session ends	March 13	First short session ends
October 13	Second short session begins (ends on same schedule as 16-week classes)	March 14	Second short session begins (ends on same schedule as 16-week classes)
October 18	16-week Midterm Grades Due	March 20	Spring Break begins, 7:00 a.m.
October 18	Faculty Work Day (no day or night classes)	March 23-26	Technology Maintenance (Canvas and online services may not be available)
October 25	14-week Midterm Grades Due	March 27	Spring Break ends, 7:00 a.m.
November 11	Veterans' Day (campus closed)	March 28	16-week Midterm Grades Due
November 23	Thanksgiving recess begins, 12:00 p.m.	April 7	Spring Holiday begins, 7:00 a.m.
November 25-27	Technology Maintenance (Canvas and online services may not be available)	April 10	Spring Holiday ends, 7:00 a.m.
November 28	Thanksgiving recess ends, 7:00 a.m.	April 11	14-Week Midterm Grades Due
December 5	Last meeting for Monday only classes (one time a week day/night classes)	May 4	Last meeting for Thursday only classes (one time a week day/night classes)
December 6	Last meeting for Tuesday only classes (one time a week day/night classes)	May 9	Last Day of Classes (TR)
December 7	Last meeting for Wednesday only classes (one time a week day/night classes)	May 9	Last meeting for Tuesday only classes (one time a week day/night classes)
December 8	Last Day of Classes (TR)	May 10	Last meeting for Wednesday only classes (one time a week day/night classes)
December 8	Last meeting for Thursday only classes (one time a week day/night classes)	May 11	No classes scheduled; teaching faculty not required to be on campus.
December 9	Last Day of Classes (MWF)	May 12	Last Day of Classes (MWF)
December 9	Last meeting for Friday only classes (one time a week day/night classes)	May 12	Last meeting for Friday only classes (one time a week day/night classes)
December 17	Last meeting for Saturday classes (one time a week classes)	May 13	Last meeting for Saturday classes (one time a week classes)
December 12-17	Final Exams (see Final Examination Schedule for further clarification)	May 15	Last meeting for Monday only classes (one time a week day/night classes)
December 20	<b>Grades Due, 12:00 p.m.</b>	May 15-19	Final Exams (see Final Examination Schedule for further clarification)
		May 20	Commencement
		May 23	<b>Grades Due, 12:00 p.m.</b>
WINTER INTERSESSION 2022		SUMMER INTERSESSION 2023	
December 19	Classes Begin	May 22	Classes Begin
December 26	Christmas recess (observed) begins, 7:00 a.m.	May 29	Memorial Day recess begins, 7:00 a.m.
December 27	Christmas recess (observed) ends, 7:00 a.m.	May 30	Memorial Day recess ends, 7:00 a.m.
January 2	New Year's recess (observed) begins, 7:00 a.m.	June 8	Last Day of Spring Intersession Classes
January 3	New Year's recess (observed) ends, 7:00 a.m.	June 13	<b>Intersession Grades Due, 12:00 p.m.</b>
January 10	Last Day of Winter Intersession Classes		<b>SUMMER 2023</b>
January 12	<b>Intersession Grades Due, 12:00 p.m.</b>	June 12	Classes Begin
		July 2-5	Technology Maintenance (Canvas and online services may not be available)
		July 4	Independence Day (campus closed)
		July 6	First 4-week session ends
		July 10	Second 4-week session begins
		July 20	6-week sessions end
		July 25	<b>6-week Grades Due, 12:00 p.m.</b>
		August 3	8-week and second 4-week sessions end
		August 8	<b>8-week Grades Due, 12:00 p.m.</b>

# INDEX

## A

Academic Calendar.....	62
Academic Probation, Suspension and Readmission Guidelines.....	54
Academic Success Center.....	13
Academic Support Services.....	13
Accreditation.....	2
Administrative Withdrawal.....	58
Agreement For Success.....	61
Apply for Graduation.....	8
Admissions.....	11
Advising.....	11

## B

Black Student Union.....	8
--------------------------	---

## C

Campus Who's Who.....	60
Campus Police.....	11
Canceled Classes.....	7
Care Team.....	11
Cell Phone Use Policy.....	51
Class Attendance Policy.....	58
Complaints Alleging Discrimination or Harassment Procedure.....	28
Computer Use Policy.....	49
Counseling Services.....	11

## D

Directory of Services.....	5
Disability Support Services.....	14
Drug Free Work Place Guidelines.....	60

## E

Early Childhood Center.....	12
Enrollment Services.....	12
Evacuation Routes.....	64

## F

Faculty Office Hours.....	60
Federal Disclosure Information.....	53
FERPA.....	51
Field House Activity Guidelines.....	10
Financial Aid.....	12
Financial Aid Guidelines.....	55
Financial Aid Implications Related to Attendance.....	58
Fitness Center.....	10
Floor Plans.....	64
Foundations Lab.....	14

## G

Gender-Neutral Restrooms.....	6
Grade Appeal Process.....	59

## L

Lactation Rooms.....	6
Learning Express Library.....	14
Legion of Gamers.....	9
LGBTQ+.....	9
Library Services.....	15

## M

Math Lab.....	14
Medical Withdrawal.....	59
Minimum Standards Academic Progress.....	54
Mission, Vision, Values.....	7

## N

National Association for Music Education (NAfME).....	9
National Society of Leadership & Success.....	9
Navigators.....	8
Non-Discrimination Notice.....	2

## O

Official Student Records.....	51
Online Courses.....	16

## P

Parking Sticker.....	7
Peer Tutoring.....	15
Phi Theta Kappa.....	8
Prohibition Policy Against Drug and Alcohol Abuse.....	48
Project SUCCESS.....	12
Psychology Club.....	9

## Q

Questions & Answers.....	7
--------------------------	---

## R

Residential Life.....	12
Rules of Procedure Student Disciplinary Matters.....	18
Recommended Procedures Survivors Should Follow in the Case of Alleged Dating Violence, Domestic Violence, Sexual Assault, or Stalking.....	21

## S

Science Lab.....	14
Services for Students.....	11
Sports at Jefferson College.....	10
Student Appeal Process.....	52
Student Code of Conduct.....	16
Student Development.....	12
Student ID.....	7
Student Missouri National Education Association (SMNEA).....	9
Student Nurse Club.....	9
Student Organizations.....	8
Student Records.....	51
Student Senate.....	9
Student Support Services (Project SUCCESS).....	12

## T

Testing Services.....	15
Text Messaging.....	7
Title IV Funds.....	57
Tutoring Services.....	15

## U

U.S. Department of Education Return of Title IV Funds.....	57
--	----

## V

Vikings Care.....	13
-------------------	----

## W

Withdrawing, Dropping, & Adding Courses.....	59
Workforce and Employment Services.....	13
Writing Club.....	8
Writing Lab.....	14



# FLOOR PLANS AND EVACUATION ROUTES

## FIELD HOUSE (FH)

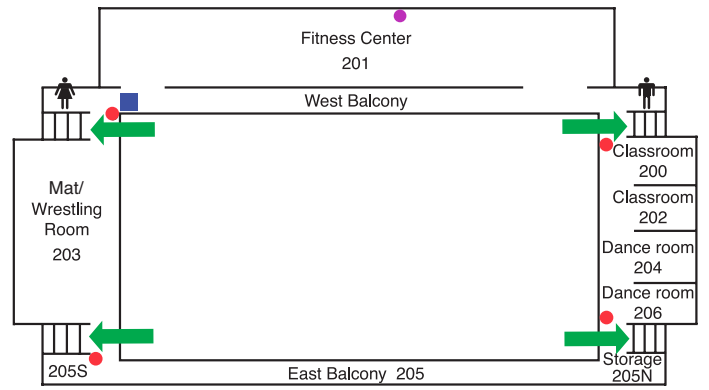
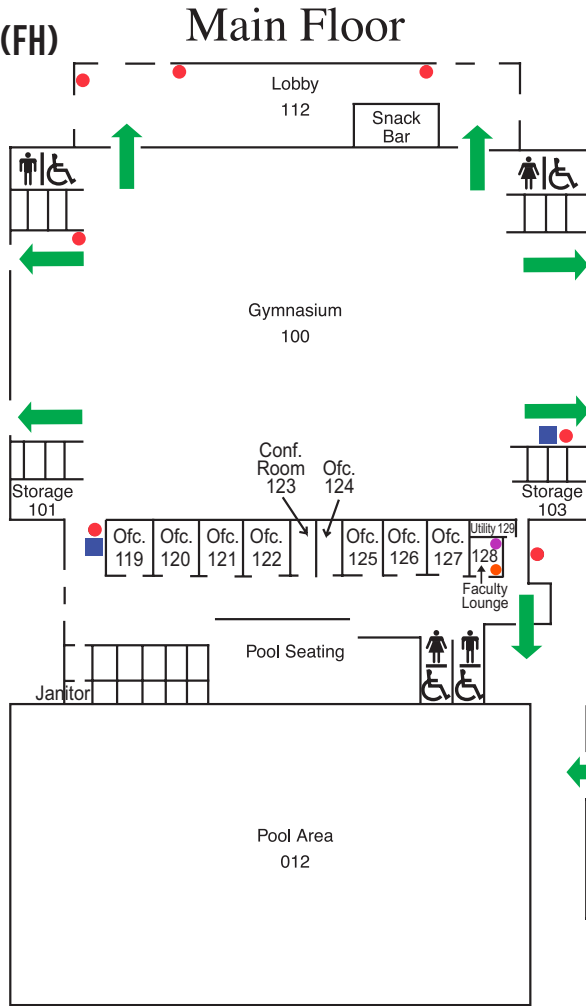

## Lower Level

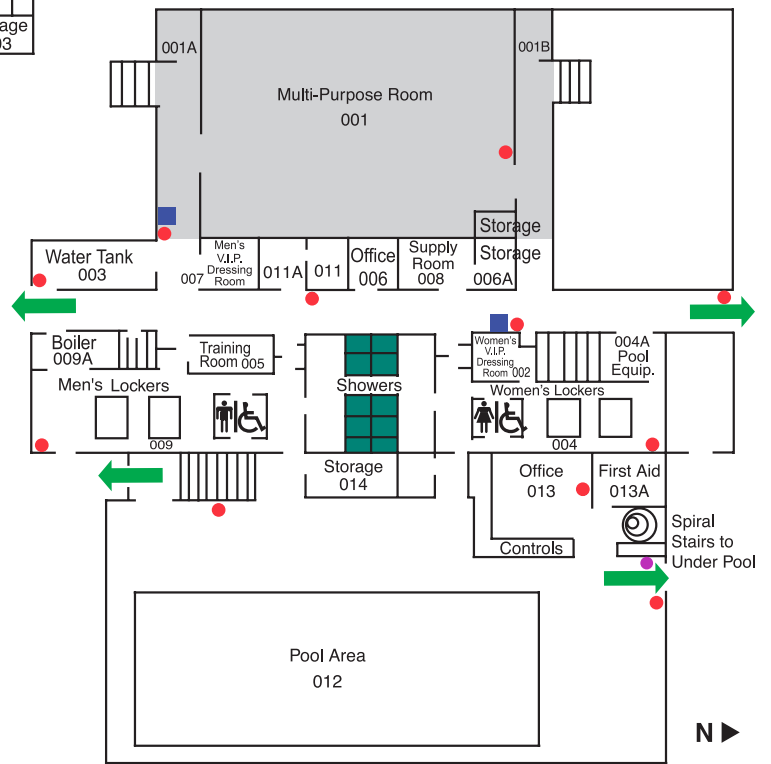

## ARTS & SCIENCES I (ASI)

### First Floor

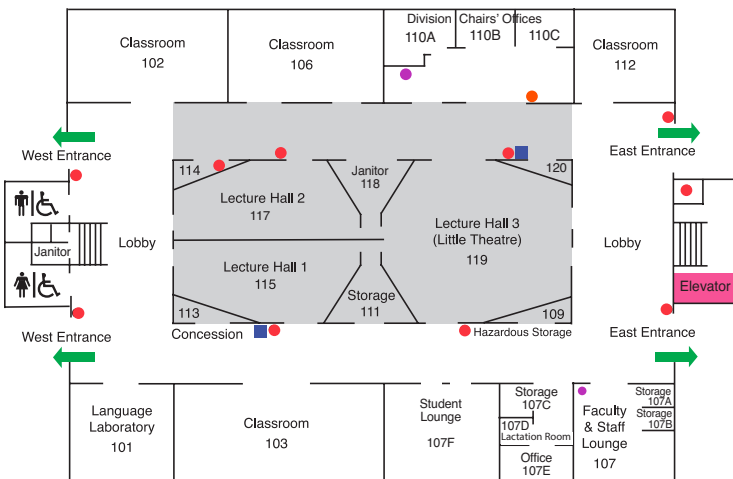

### Second Floor

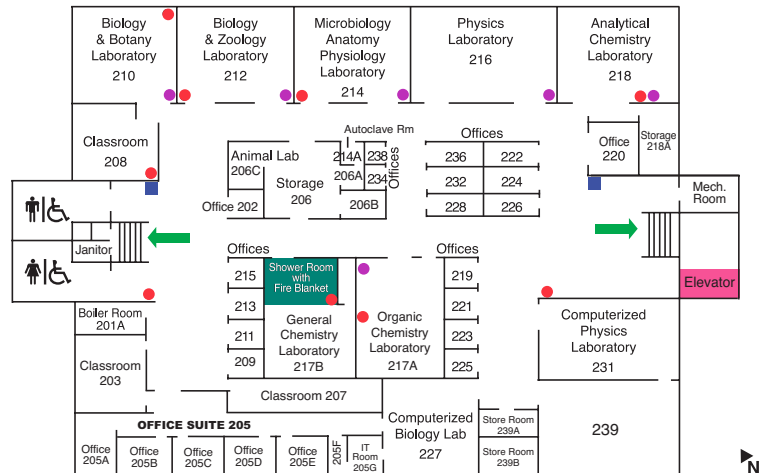

# ARTS & SCIENCES II (ASII)

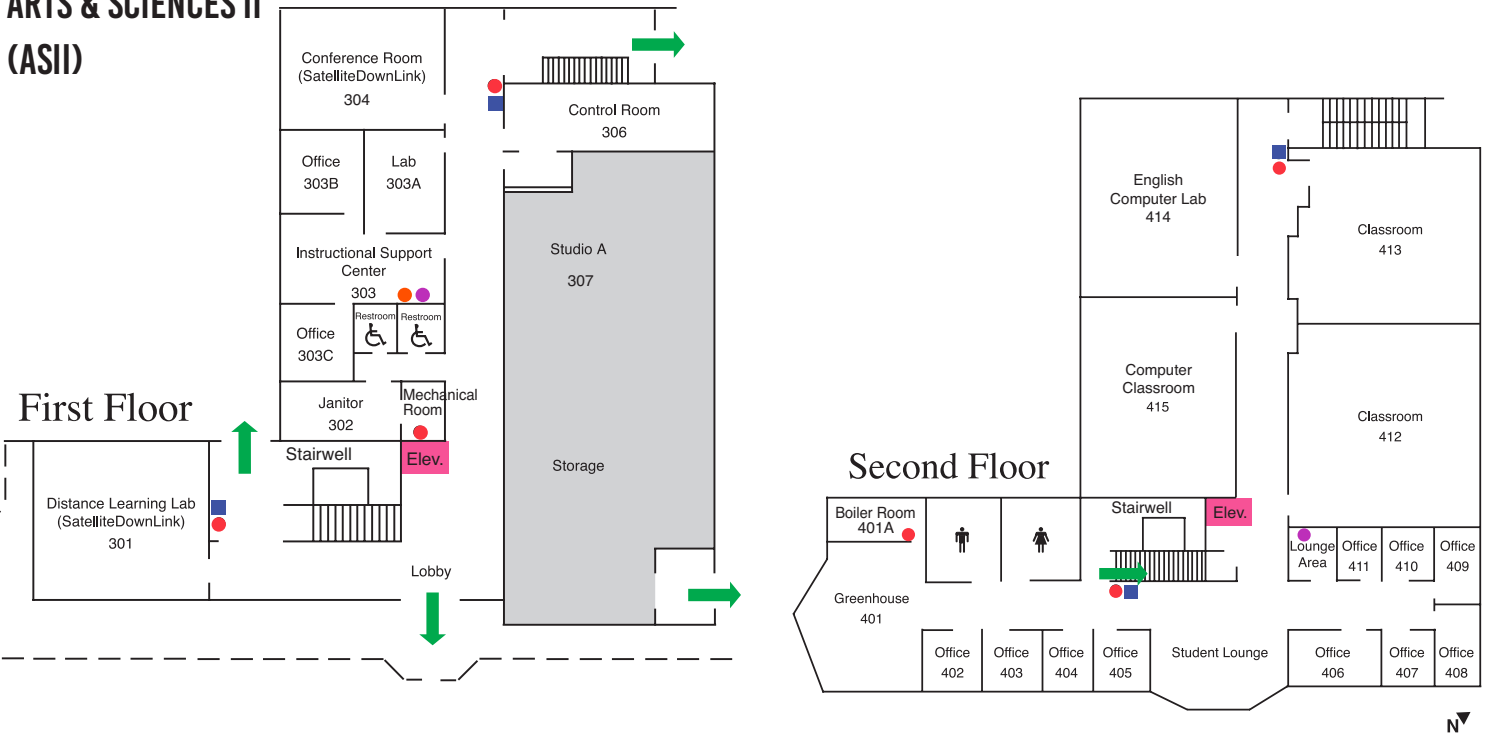

# AREA TECHNICAL SCHOOL (ATS)

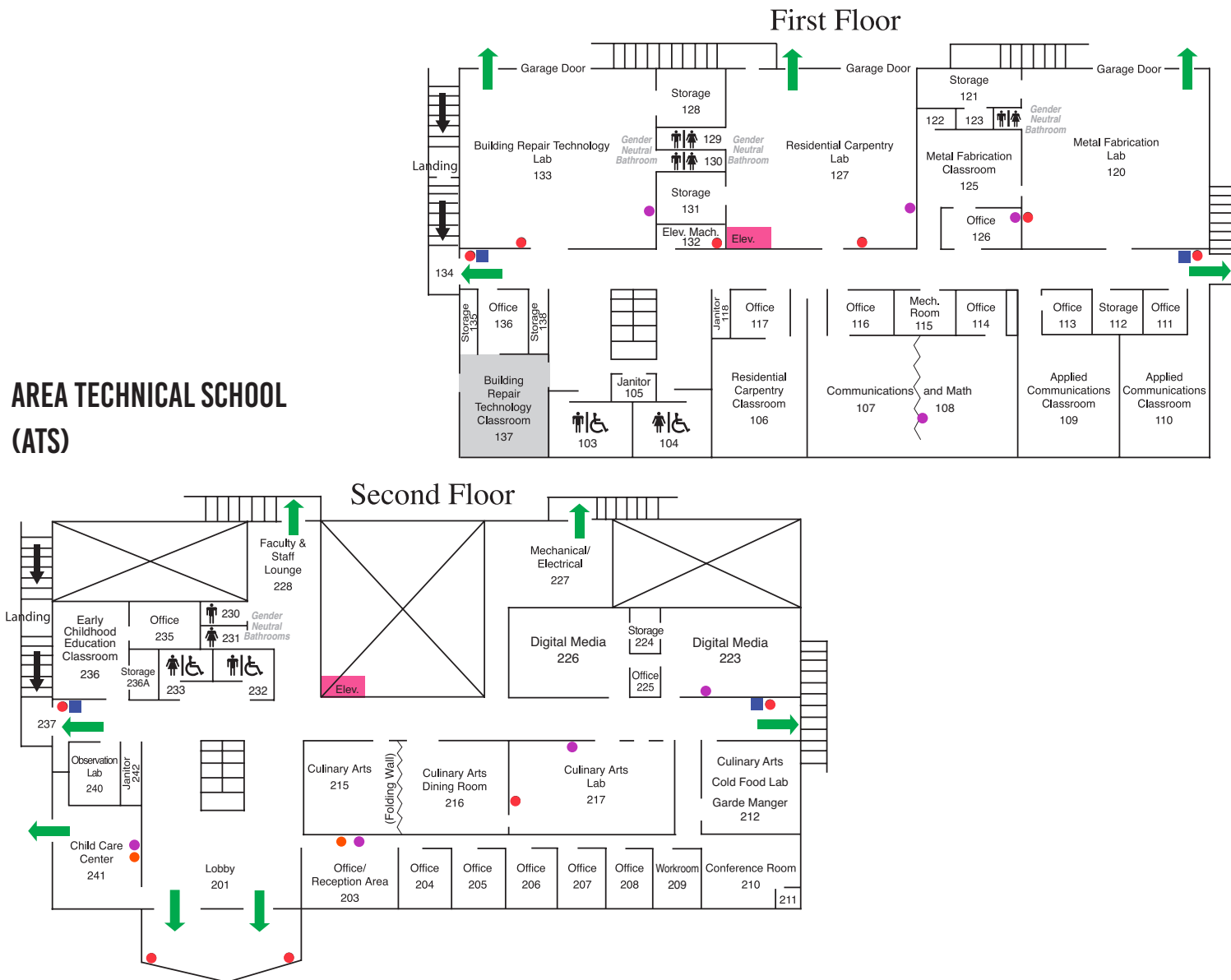

# EARLY CHILDHOOD CENTER (ECC)

## First Floor

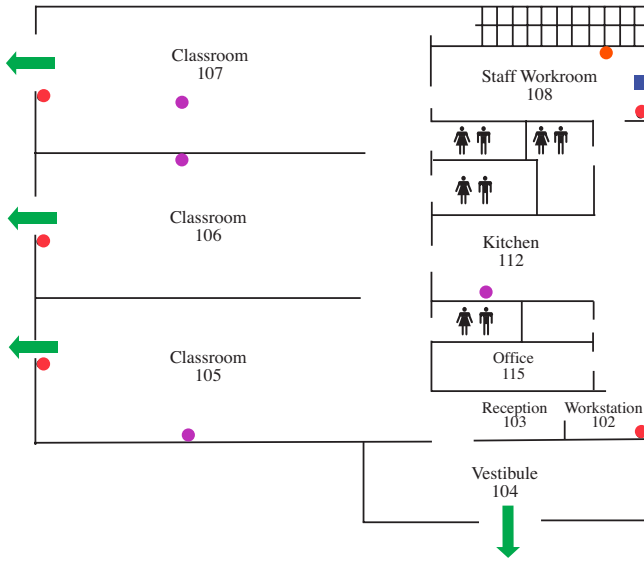

## Lower Level

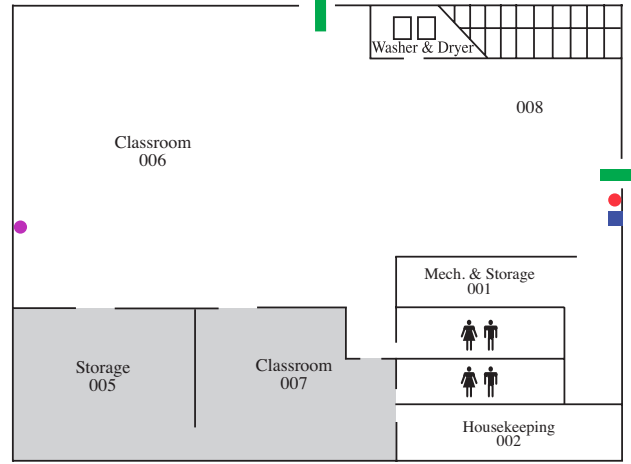

# CAREER & TECHNICAL EDUCATION (CTE)

## First Floor

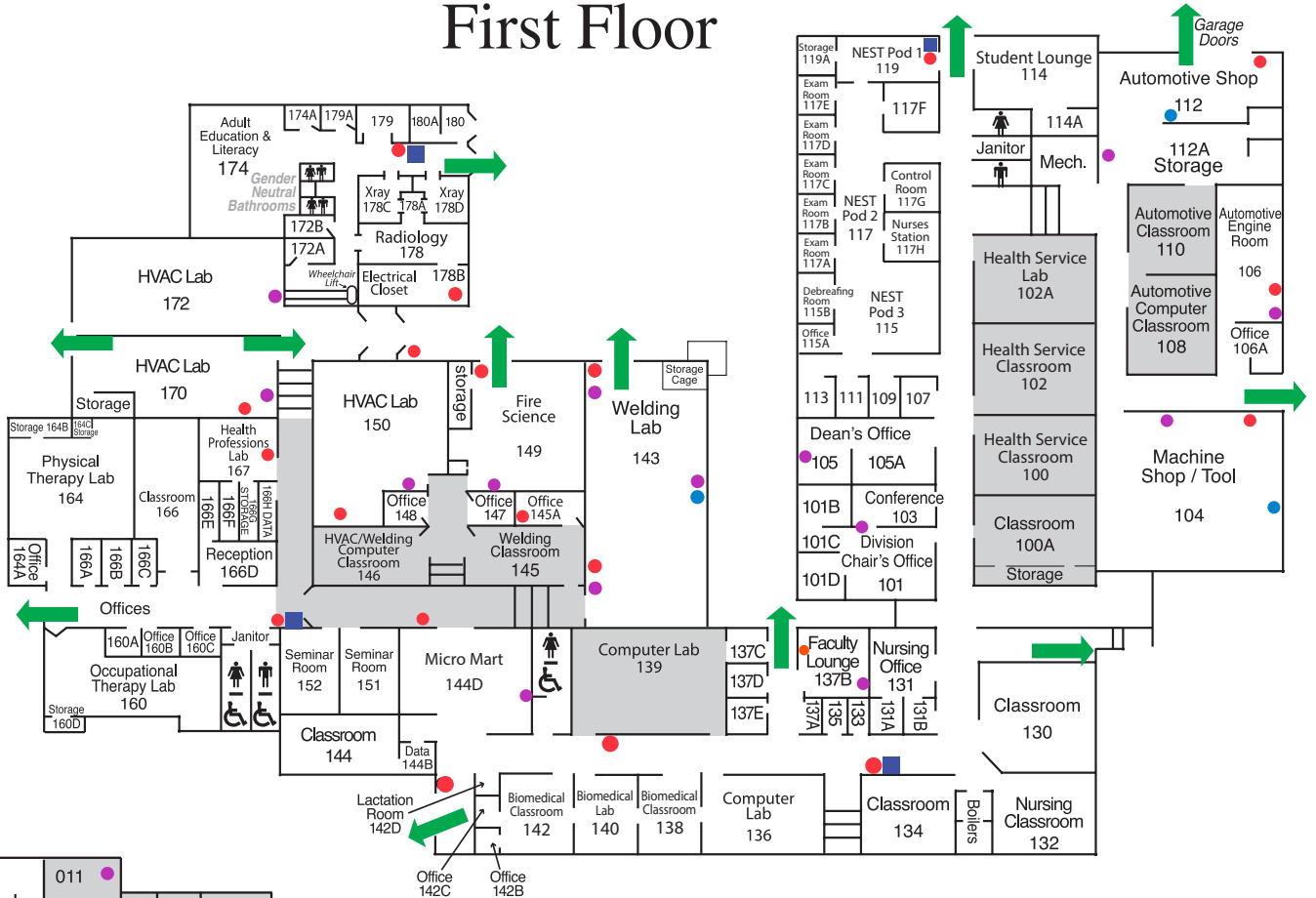

## Lower Level

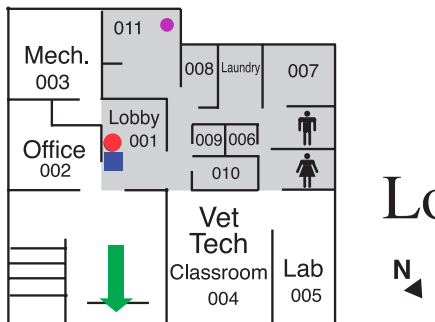

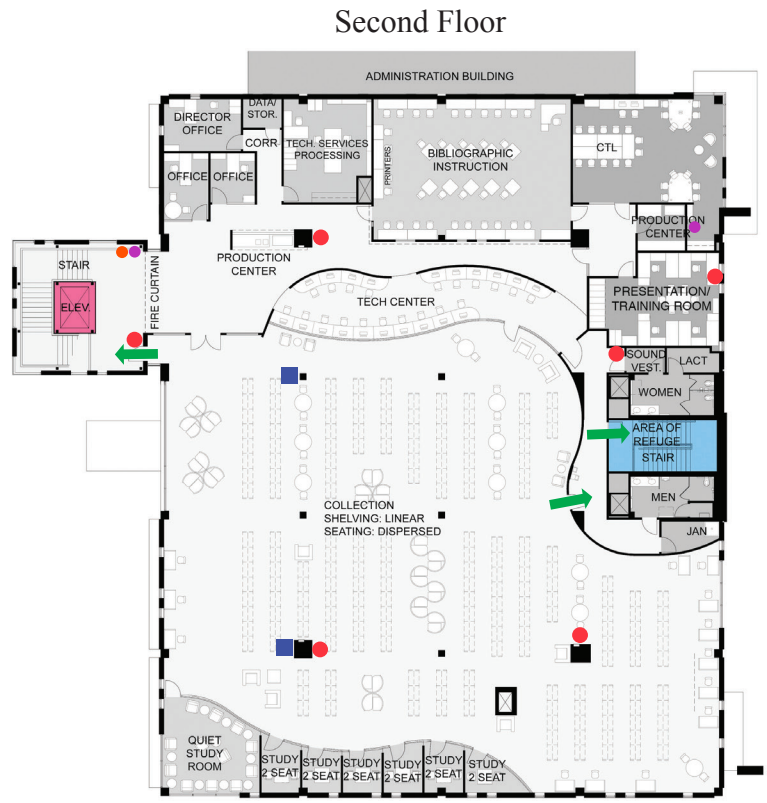
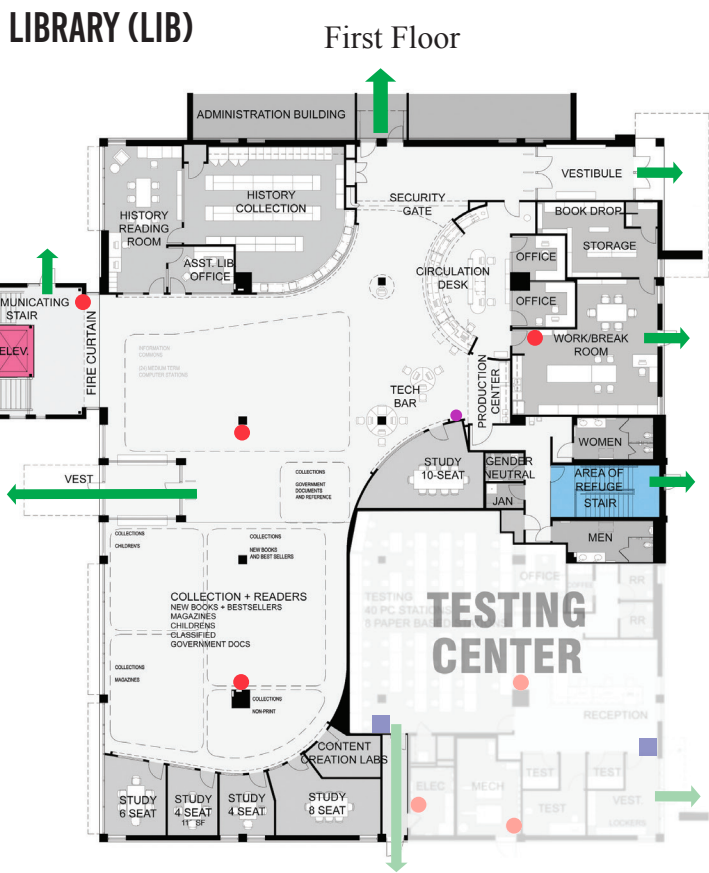
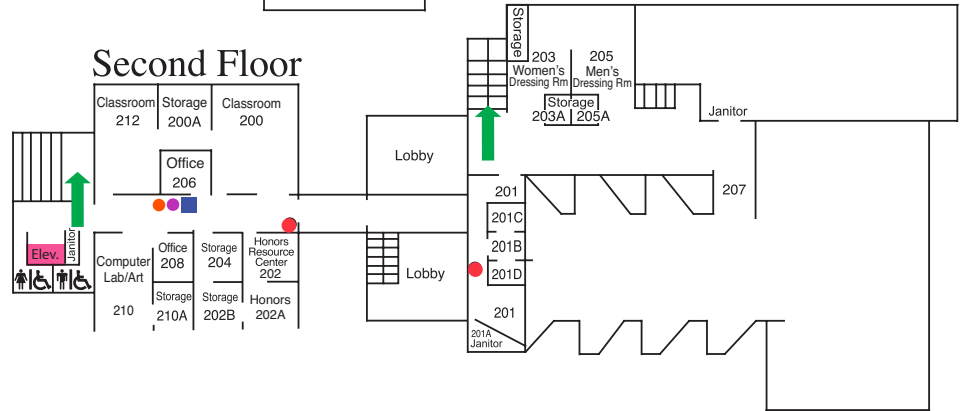
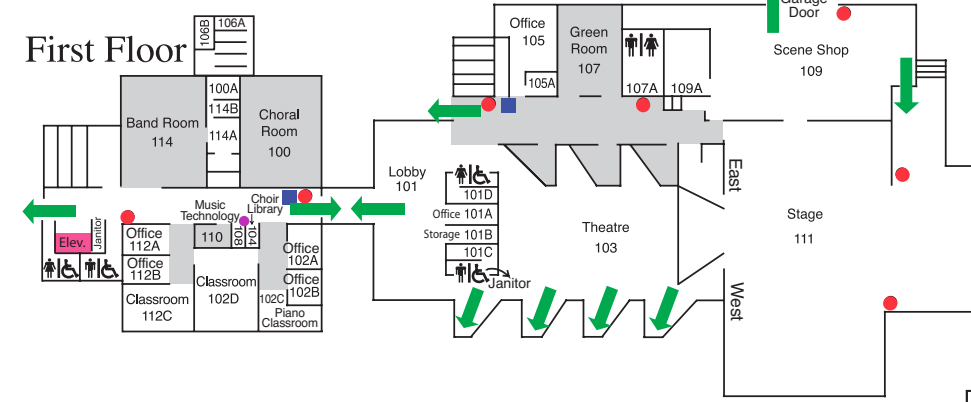
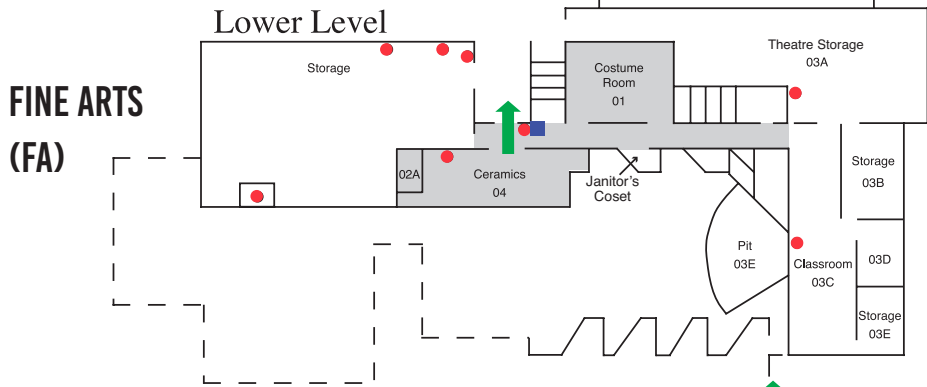

# STUDENT CENTER (SC)

## Lower Level

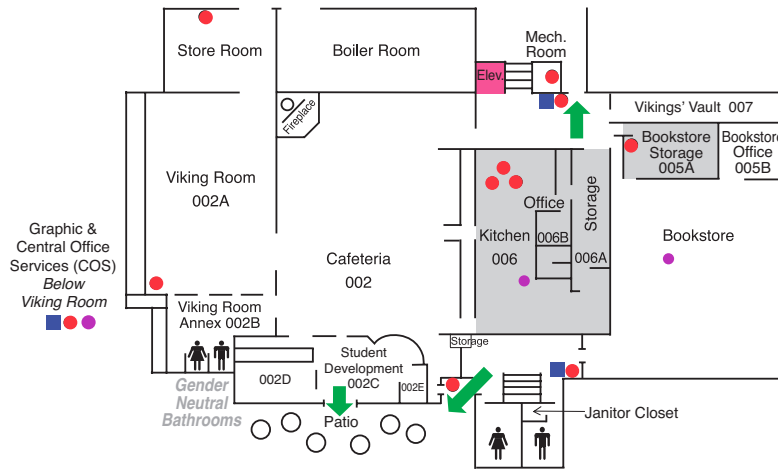

## First Floor

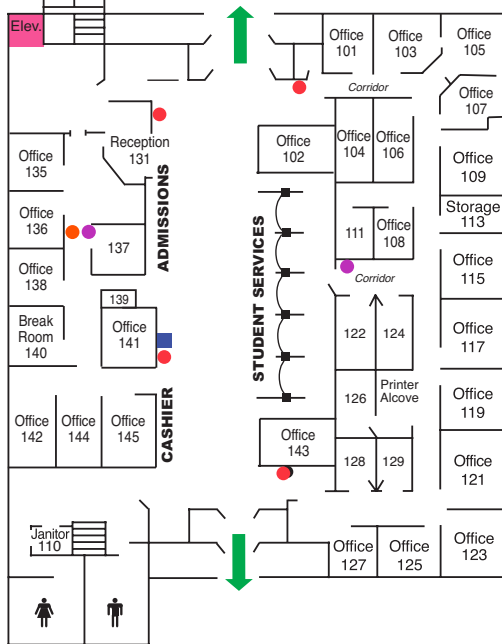

## Second Floor

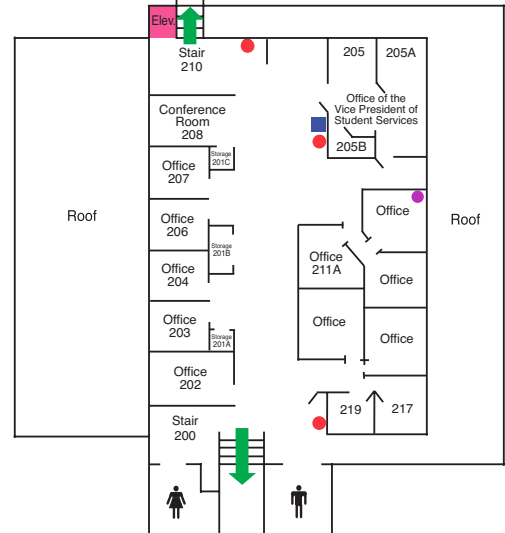

# TECHNOLOGY BUILDING (TC)

## First Floor

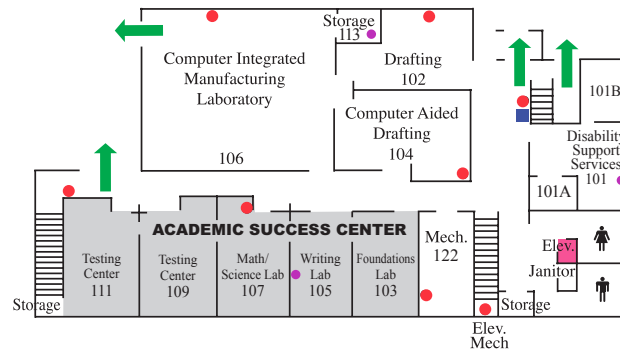

## Second Floor

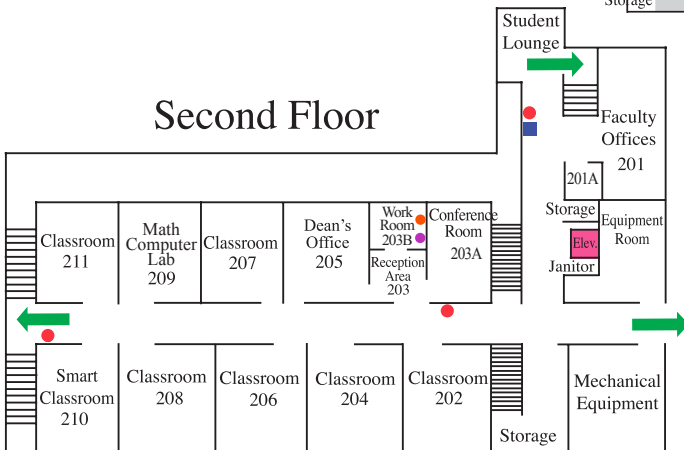

## Third Floor

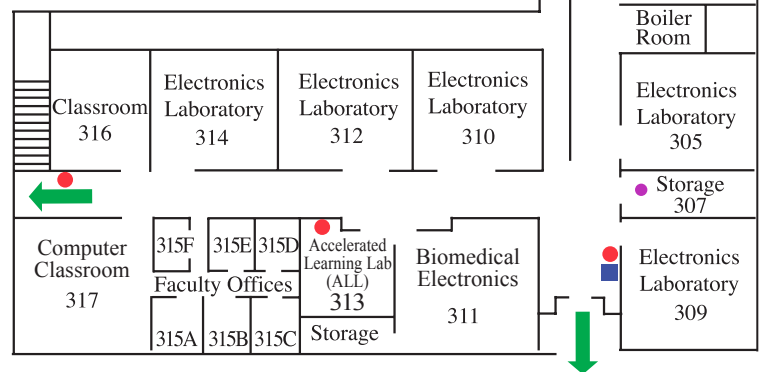



# BUILDINGS & GROUNDS (BG)

## Lower Level

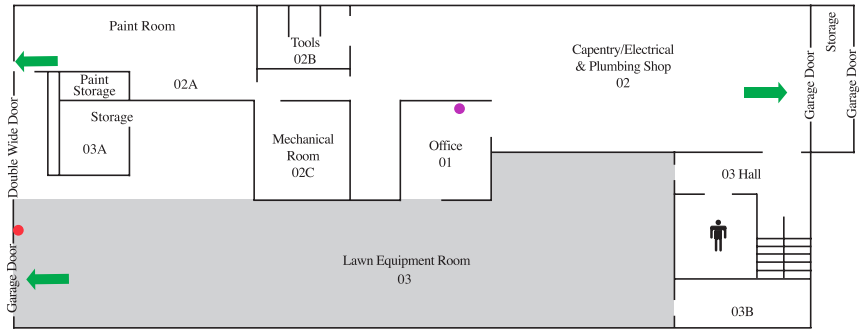

## First Floor

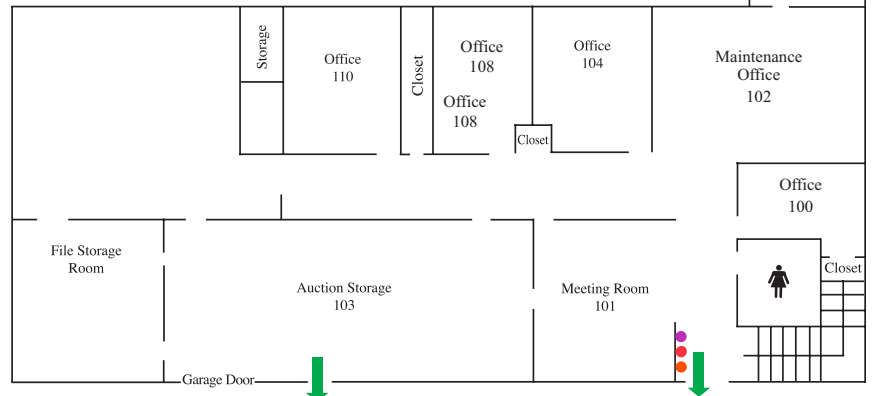

# ADMINISTRATION BUILDING (ADMN)

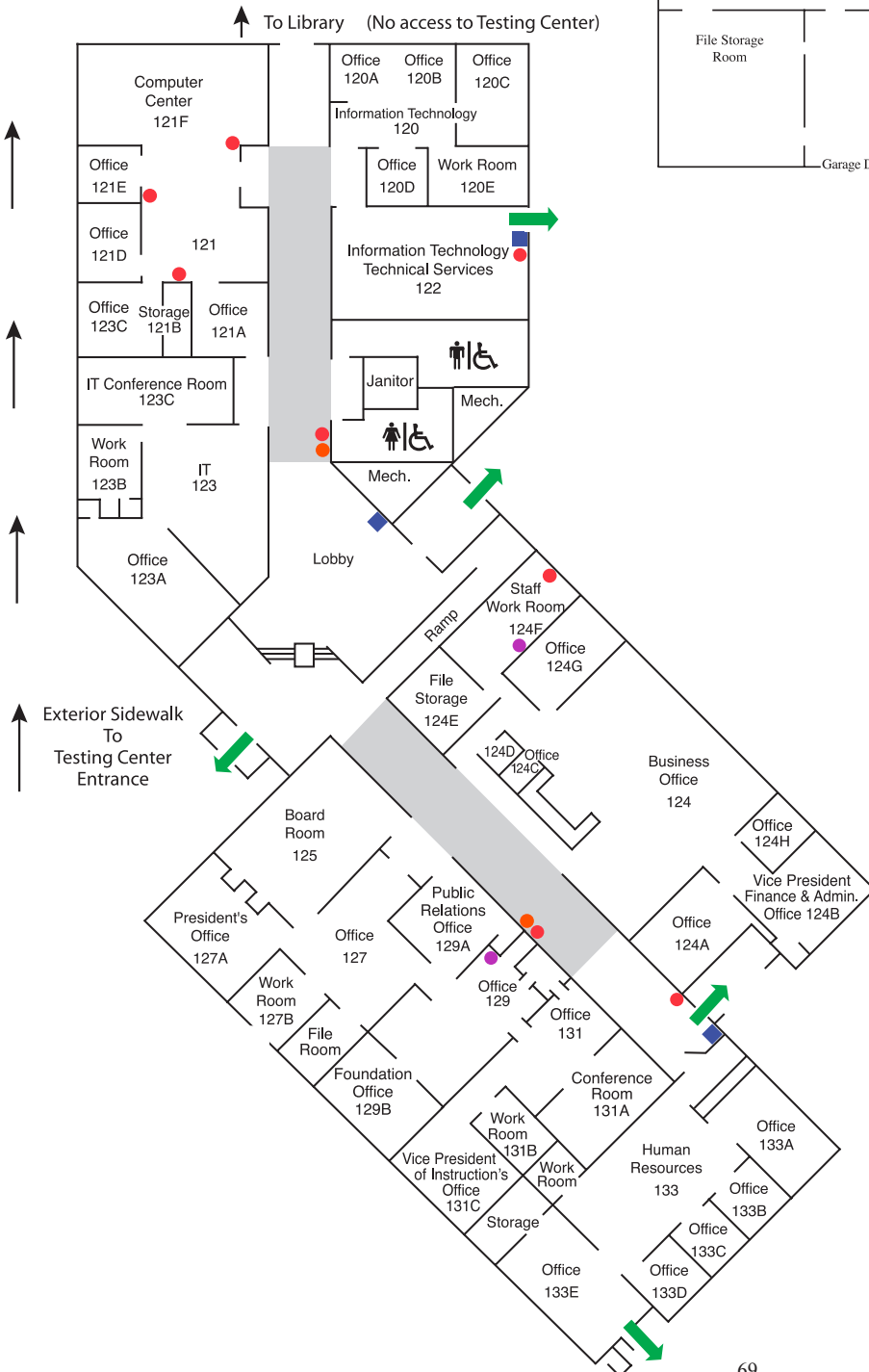

# JEFFERSON COLLEGE ARNOLD (JCA)

## First Floor

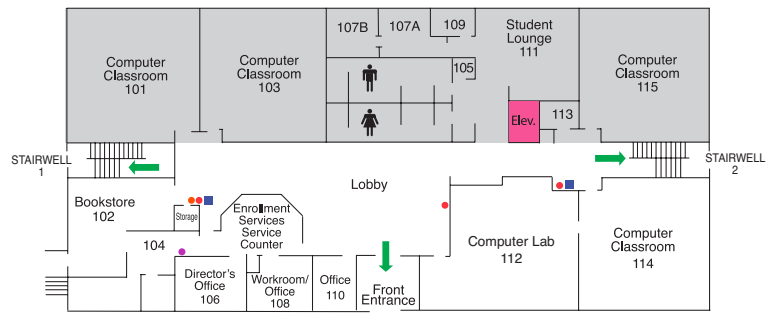

## Second Floor

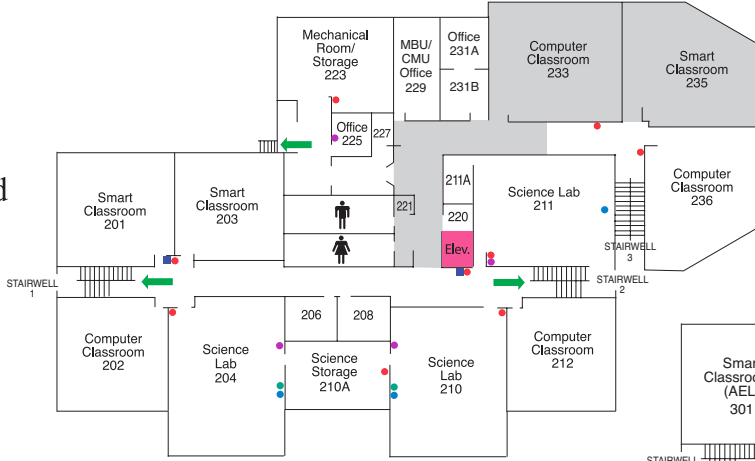

## Third Floor

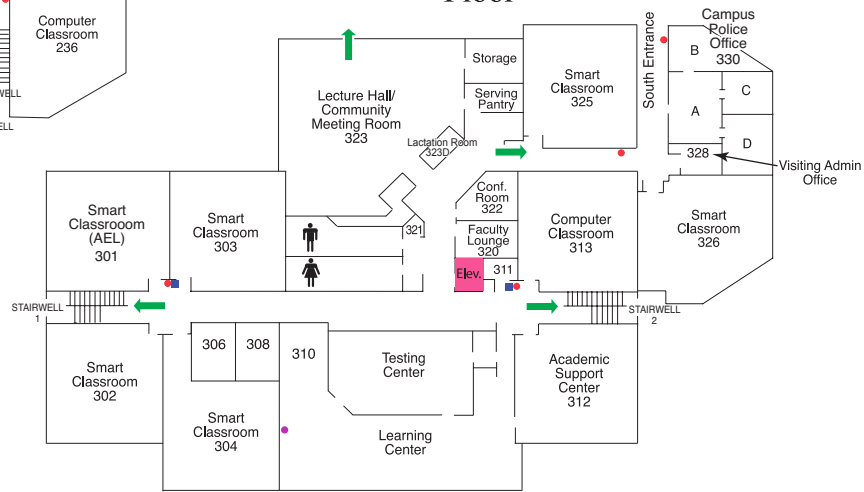

# JEFFERSON COLLEGE IMPERIAL (JCI)

## Lower Level

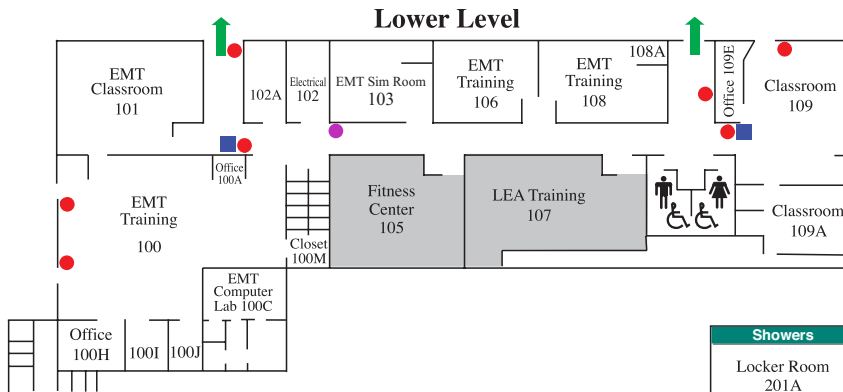

## Upper Level

